

SEIFERT SURFACES, COMMUTATORS AND VASSILIEV INVARIANTS

EFSTRATIA KALFAGIANNI AND XIAO-SONG LIN

ABSTRACT. We show that the Vassiliev invariants of a knot K , are obstructions to finding a regular Seifert surface, S , whose complement looks “simple” (e.g. like the complement of a disc) to the lower central series of its fundamental group. We also conjecture characterization of knots whose invariants of all orders vanish in terms of their Seifert surfaces.

Key words: Knot, lower central series, n -hyperbolic, n -trivial, Seifert surface, Vassiliev invariants.

Mathematics Subject Classification 2000: 57M25, 57N10

1. INTRODUCTION

We show that the Vassiliev knot invariants provide obstructions to a knot’s bounding a *regular* Seifert surface whose complement looks, modulo the lower central series of its fundamental group, like the complement of a null-isotopy. Before we state the main results of this paper, let us introduce some notation and terminology. We will say that a Seifert surface S of a knot K is *regular* if it has a spine Σ whose embedding in S^3 , induced by the embedding $S \subset S^3$, is isotopic to the standard embedding of a bouquet of circles. Such a spine will be called a *regular spine* of S . In particular, $\pi := \pi_1(S^3 \setminus S)$ is a free group. A key idea we will introduce is to define *n -hyperbolic* Seifert surfaces. Roughly speaking, these are surfaces whose complement looks, modulo certain terms of the lower central series of its fundamental group, like the complement of a Seifert surface of a trivial knot. A knot bounding such a surface is called *n -hyperbolic*. We prove the following:

Theorem 1.1. *There exists a sequence of natural numbers $\{l(n)\}_{n \in \mathbb{N}}$, with $l(n) > \log_2\left(\frac{n-5}{144}\right)$ such that the following is true: If K is n -hyperbolic, then all the Vassiliev invariants of orders $\leq l(n)$ of K vanish. In particular, if K is n -hyperbolic for all $n \in \mathbb{N}$ then all the Vassiliev invariants of K vanish.*

The authors’s research is partially supported by the NSF.
September 11, 2007.

A question arising from this work is whether the notion of n -hyperbolicity provides a complete geometric characterization of n -trivial knots. We conjecture that this is the case. More precisely we have the following conjecture; further evidence of the conjecture is provided in [AK].

Conjecture 1.2. *A knot K is n -trivial for all $n \in \mathbb{N}$ if and only if it is n -hyperbolic for all $n \in \mathbb{N}$.*

Let us now describe in more detail the contents of the paper and some of the ideas that are involved in the proofs of the main results. In §2 we recall basic facts about Vassiliev invariants and the results from [Gu] that we use in subsequent sections. In §3 we study regular Seifert surfaces of knots. We introduce the notion of *good position* for bands in projections of Seifert surfaces. Let B be a band of a regular Seifert surface S , which is assumed to be in band-disc form, and let γ denote the core of B . Also, let γ^ϵ denote a push-off of γ . The main feature of a projection of S with respect to which B is in *good position* is the following: We may find a word W , in the free generators of $\pi := \pi_1(S^3 \setminus S)$, representing γ^ϵ and such that every letter in W is realized by a band crossing in the projection. In §4 we introduce *n -hyperbolic* regular Seifert surfaces and we prove Theorem 1.1. The special projections of §3 allow us to connect Gussarov’s notion of *n -triviality* to an algebraic n -triviality in π , and exhibit a correspondence between geometry in $S^3 \setminus S$ and algebra in π . Let us explain this in some more detail. By Gussarov ([Gu]), to prove Theorem 1.1 it will be enough to show that an *n -hyperbolic* knot has to be $l(n)$ -trivial. Showing that a knot is *k -trivial* amounts to showing that it can be unknotted in $2^{k+1} - 1$ ways by changing crossings in a fixed projection. Having the projections of §2 at hand, the main step in the proof of Theorem 2 becomes showing the following: If γ is the core of a band B in *good position* and $\gamma^\epsilon \in \pi^{(m+1)}$, then we can trivialize B in $2^{l(m)+1} - 1$ ways (for the precise statement see Proposition 4.4). Here $\pi^{(m+1)}$ denotes the $(m+1)$ -th term of the lower central series of π . The proof of Proposition 4.4 is based on a careful analysis of the geometric combinatorics of projections of the sub-arcs of γ representing simple commutators. We show that eventually γ may be decomposed into a disjoint union of “nice” arcs for which the desired conclusion follows by Dehn’s Lemma.

The lower central series first appeared in the theory of Vassiliev invariants in the work of Stanford ([S],[S1]). The paper [KL], was the first place where commutators were brought in the theory of Vassiliev invariants from a geometric point of view. Since the appearance of [KL] the theory of geometric commutators and Vassiliev’s invariants was developed via the theory of grope cobordisms and led to beautiful geometric characterizations of the invariants ([Ha], [CT]). The contents of this paper are partly based on material in [KL] but has undergone major revisions. The Seifert surfaces

introduced here, can be fit into the framework of geometric gropes and from this point of view the main result here has similar flavor to this of [CT]. The advantage of the point of view taken here is that the objects of study are Seifert surfaces which are very familiar to knot theorists. On the other hand, unlike in the case of immersed gropes, it is not known whether our n -hyperbolic surfaces completely characterize knots with trivial Vassiliev invariants: As said, Conjecture 1.2 is only partially verified at this time. We should also point out that the properties of n -hyperbolic knots have also been studied in the articles of L. Plachta ([P], [P1]), where also some of the questions asked in [KL] are answered.

This paper was completed and submitted in July 2006. While the paper was under review for publication, Xiao-Song Lin passed away (on January 14, 2007), after a short period of illness. His untimely death left us with a profound loss.

2. GUSSAROV'S n -TRIVIALITY

A *singular knot* $K \subset S^3$ is an immersed curve whose only singularities are finitely many transverse double points.

Let \mathbb{K}_n be the rational vector space generated by the set of ambient isotopy classes of oriented, singular knots with exactly n double points. In particular $\mathbb{K} = \mathbb{K}_0$ is the space generated by the set of isotopy classes of oriented knots.

A knot invariant V can be extended to an invariant of singular knots by defining

$$\begin{array}{c} \diagup \diagdown \\ \diagdown \diagup \end{array} = \begin{array}{c} \diagup \diagdown \\ \diagdown \diagdown \end{array} - \begin{array}{c} \diagup \diagdown \\ \diagup \diagup \end{array}$$

for every triple of singular knots which differ at one crossing as indicated. In particular, \mathbb{K}_n can be viewed as a subspace of \mathbb{K} for every n , by identifying any singular knot in \mathbb{K}_n with the alternating sum of the 2^n knots obtained by resolving its double points. Hence, we have a subspace filtration

$$\dots \subset \mathbb{K}_n \dots \subset \mathbb{K}_2 \subset \mathbb{K}_1 \subset \mathbb{K}$$

Definition 2.1. *Vassiliev knot invariant of order $\leq n$ is a linear functional on the space $\mathbb{K}/\mathbb{K}_{n+1}$. The invariants of order $\leq n$ form a subspace \mathbb{V}_n of \mathbb{K}^* , the annihilator of the subspace $\mathbb{K}_{n+1} \subset \mathbb{K}$. We will say that an invariant v is of order n if v lies in \mathbb{V}_n but not in \mathbb{V}_{n-1} .*

Clearly, we have a filtration

$$\mathbb{V}_0 \subset \mathbb{V}_1 \subset \mathbb{V}_2 \subset \dots$$

To continue we need to introduce some notation. Let $D = D(K)$ be a diagram of a knot K , and let $\mathbb{C} = \mathbb{C}(D) = \{C_1, \dots, C_m\}$ be a collection of disjoint non-empty sets of crossings of D . Let us denote by $2^{\mathbb{C}}$ the set of all

subsets of \mathbb{C} . Finally, for an element $C \in 2^{\mathbb{C}}$ we will denote by D_C the knot diagram obtained from D by switching the crossings in all sets contained in C . So, all together, we can get 2^m different knot diagrams from the pair (D, \mathbb{C}) . Notice that each $C_i \in \mathbb{C}$ may contain more than one crossings.

Definition 2.2. ([Gu]) *Two knots K_1 and K_2 are called n -equivalent, if K_1 has a knot diagram D with the following property: There exists $\mathbb{C} = \{C_1, \dots, C_{n+1}\}$, a collection of $n+1$ disjoint non-empty sets of crossings of D , such that D_C is a diagram of K_2 for every non empty $C \in 2^{\mathbb{C}}$. A knot K which is n -equivalent to the trivial knot will be called n -trivial*

Theorem 2.3. ([Gu], [NS]) *Two knots K_1 and K_2 are n -equivalent if and only if all of their Vassiliev invariants of order $\leq n$ are equal. In particular, a knot K is n -trivial if and only if all its Vassiliev invariants of order $\leq n$ vanish.*

3. SEIFERT SURFACES

3.1. Generalities. Let K be an oriented knot in S^3 . A *Seifert surface* of K is an oriented, compact, connected, bi-collared surface S , embedded in S^3 such that $\partial S = K$.

A *spine* of S is a bouquet of circles $\Sigma \subset S$, which is a deformation retract of S .

Definition 3.1. *A Seifert surface S of a knot K is called regular if it has a spine Σ whose embedding in S^3 , induced by the embedding $S \subset S^3$, is isotopic to the standard embedding of a bouquet of circles. We will say that Σ is a regular spine of S .*

Let $\Sigma_n \subset S^3$, be a bouquet of n circles based at a point p . A regular projection of Σ_n is a projection of Σ_n onto a plane with only transverse double points as possible singularities. Starting from a regular projection of Σ_n , we can construct an embedded compact oriented surface as follows: On the projection plane, let D^2 be a disc neighborhood of the base point p , which contains no singular points of the projection. Then, D^2 intersects the projection of Σ_n in a bouquet of $2n$ arcs and there are n arcs outside D^2 . We first replace each of the arcs outside D^2 by a flat band with the original arc as its core. Here a band being flat means we have an immersion when the band is projected onto the plane. That is to say that the only singularities the band projection has are these at the double points of the original arc projection so that bands overlap themselves exactly when the arcs over cross themselves.

Let S denote the surface obtained by the union of the disc D^2 and these flat bands, to which some full twists are added if necessary. We say that S is a surface *associated* to the given regular plane projection of Σ_n . We will also say that the surface S is in a *disc-band form*. A *band crossing* of S is

obviously defined, and they are in one-one correspondence with crossings on the regular plane projection of Σ_n . We certainly have the freedom to move the full twists added to the bands anywhere. So we assume that all the twists of the band are moved near the ends of the bands. We may sometimes abuse the notation by not distinguishing a band and its core and only take care of the twists at the end of an argument.

Now let S be a regular surface of genus g . Pick a base point $p \in S$, and let Σ_n , $n = 2g$, be a regular spine of S such that p is the point on Σ_n where all circles in Σ_n meet. Let $\gamma_1, \beta_1, \dots, \gamma_g, \beta_g$ be the circles in Σ_n oriented so that they form a symplectic basis of $H_1(S)$. Assume further that a disc neighborhood of p in S is chosen so that its intersection with Σ_n consists of $2n$ arcs.

Lemma 3.2. *Let S be a regular Seifert surface, with Σ_n a regular spine. The embedding $\Sigma_n \subset S^3$ has a regular plane projection as shown in Figure 1 below, where b is a braid of index $2n$, such that the regular Seifert surface S is isotopic to a surface associated to that projection of Σ_n .*

Proof: Let W_n be a bouquet of n circles, all based at a common point q . Then, Σ_n induces an embedding of W_n in S^3 . Let us begin with a regular plane projection of W_n , such that in a neighborhood D of q in the projection plane, the $2n$ arcs in $D \cap W_n$ are ordered and oriented in the same way as the arcs of Σ_n in the chosen disc neighborhood of p in S .

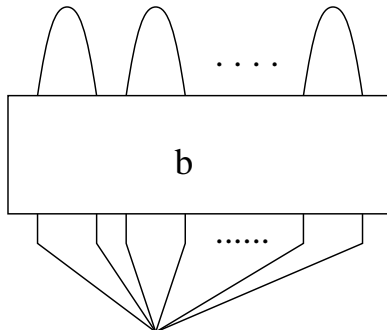

FIGURE 1. A projection of a regular spine.

Then, after a possible adjustment by adding some small kinks, S is isotopic to the surface associated to this projection. Since Σ_n is isotopic to the standard embedding of W_n in S^3 , we may switch the arcs in D , so that the arcs of Σ_n outside D are isotopic to the standard embedding. We may then record these switches by the braid b . \square

3.2. Good position of bands. Let us consider $\mathbb{R}^3 \subset S^3$ and a decomposition $\mathbb{R}^3 = \mathbb{R} \times \mathbb{R}^2$, and take the factor \mathbb{R}^2 as a fixed projection plane P from now on. Also, we will fix a coordinate decomposition (t, s) of P .

Now let l denote the t -axis on P , and let $H_+ = \{(t, s) \in P \mid s > 0\}$ and $H_- = \{(t, s) \in P \mid s < 0\}$.

To continue assume that S is a regular Seifert surface and fix a projection, $p : S \rightarrow P$ in the disc-band form. Assume that the bands (their cores) of S are all transverse to l . Let B be a band of S , and let γ be the core of B . By a *sub-band* B' of B , we mean a band on B whose core γ' is a sub-arc of γ .

Definition 3.3. *We will say that a band B is in good position with respect to the projection iff the following conditions hold:*

- a) *The band B is flat.*
- b) *For every band $A \neq B$, the intersection $H_+ \cap A$ consists of a single sub-band with no self-crossings, and these sub-bands are all disjoint.*
- c) *All the self-crossings of B occur in H_+ , and are all under crossings (resp. over crossings). Moreover, the intersection $H_+ \cap B$ consists of finitely many sub-bands B_0, B_1, \dots, B_k such that*
 - i) *they have no self-crossings;*
 - ii) *the B_j 's, $j \neq 0$, are disjoint with each other, and each crosses exactly once under (resp. over) B_0 , or one of the sub-bands in b).*
- d) *The crossings between B and any other band that occur in H_- are all over crossings (resp. under crossings).*

An example of a projection as described in Definition 3.3 is shown in Figure 6, at the end of this section.

To continue, let S be a regular Seifert surface and fix a projection as described in Lemma 3.2. Let g be the genus and let $A_1, B_1, \dots, A_g, B_g$ denote the bands of S . Moreover, let $\gamma_1, \beta_1, \dots, \gamma_g, \beta_g$ denote the cores of $A_1, B_1, \dots, A_g, B_g$, respectively. We orient the core curves so that they give a symplectic basis of $H_1(S)$. Finally, let $x_1, y_1, \dots, x_g, y_g$ be small linking circles of the bands such that

- i) $\text{lk}(x_i, \gamma_j) = \text{lk}(y_i, \beta_j) = \delta_{ij}$;
- ii) $\text{lk}(y_i, \gamma_j) = \text{lk}(x_i, \beta_j) = 0$ and
- iii) their projections on the plane P are simple curves disjoint from each other.

Clearly, $x_1, y_1, \dots, x_g, y_g$ represent free generators of $\pi_1(S^3 \setminus S)$.

Lemma 3.4. *For every band B of S , there exists a projection of S with respect to which B is in good position.*

Proof: Let us start with the projection fixed before the statement of the Lemma, and let l and H_+, H_- be as before Definition 3.3.

Let $\alpha_1, \hat{\alpha}_1, \dots, \alpha_{2g-1}, \hat{\alpha}_{2g}$ denote the hooks in Figure 1 on the top of the braid b . They are sub-bands of $A_1, B_1, \dots, A_g, B_g$, respectively. We move the projection of S so that l intersects each of the hooks at exactly two points and we have that the intersection $H_+ \cap p(S)$ is equal to $\alpha_1 \cup \hat{\alpha}_1 \cup$

$\dots \cup \alpha_{2g-1} \cup \hat{\alpha}_{2g}$. Thus the entire braid b is left below l , in H_- . To continue, we choose another horizontal line l_0 below l , so that b lies between l_0 and l , and only the disc part of the surface is left below l_0 . Finally, we draw more horizontal lines $l_1, l_2, \dots, l_m = l$ such that the braid b has exactly one crossing between l_{i-1} and l_i for $i = 1, 2, \dots, m$.

Without loss of generality we may assume that $B = A_1$.

Observe that since b is a braid, each band crossing of A_1 under some band A can be slid all the way up, by using the *finger moves* of Figure 2. That is, we can slide a short sub-band of A_1 , which is underneath A at the crossing, up following A until it becomes a small hook above l under crossing the hook of A .

To isotope the band A_1 into good position, we start with the lowest under crossing of A_1 under, say some band A , between l_{i-1} and l_i , for some i . We slide it up above l and still call the resulting band A_1 . Now between l_i and l_{i+1} , if there is an under crossing of A in the original picture, we will have two new under crossings of the modified A_1 . We slide these two new under crossings of A_1 up, above l , along the same way as we slide the under crossing of A between l_i and l_{i+1} up above l .

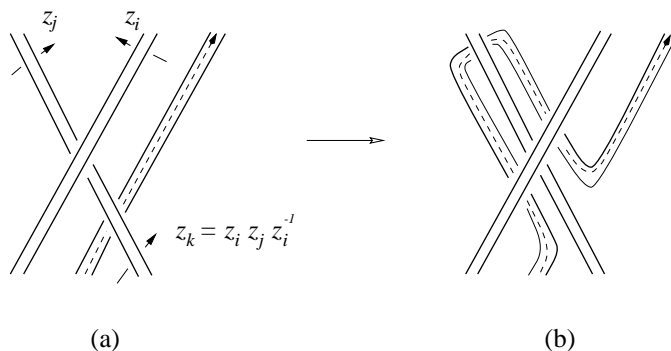

FIGURE 2. Sliding an under crossing across a band

To isotope the band A_1 into good position, we start with the lowest under crossing of A_1 under, say some band A , between l_{i-1} and l_i , for some i . We slide it up above l and still call the resulting band A_1 . Now between l_i and l_{i+1} , if there is an under crossing of A in the original picture, we will have two new under crossings of the modified A_1 . We slide these two new under crossings of A_1 up, above l , along the same way as we slide the under crossing of A between l_i and l_{i+1} up above l . Since b has only finitely many crossings, this procedure will slide all under crossings of A_1 up above l , to make A_1 in good position.

The condition a) of Definition 3.3 can also be satisfied by further isotopy which first moves the twists on the band B to a place around the line l and

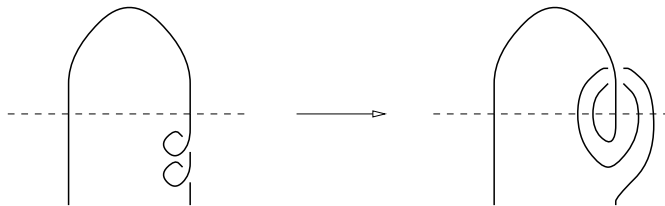

FIGURE 3. Twists on a band realized as kinks and nested kinks

then changes them to a family of “nested kinks” as illustrated in Figure 3. \square

Remark 3.5. Notice that a similar procedure can be carried out for B with over crossings replacing under crossings and vice versa.

To continue let K be a knot, and let S be a genus g Seifert surface of K . Let $N \cong S \times (-1, 1)$ be a bi-collar of S in S^3 , such that $S \cong S \times \{0\}$, and let $N^+ = S \times (0, 1)$ (resp. $N^- = S \times (-1, 0)$). For a simple closed curve $\gamma \subset S$, denote $\gamma^+ = \gamma \times \{1/2\} \subset N^+$ and $\gamma^- = \gamma \times \{-1/2\} \subset N^-$.

Now let the projection $p : S \rightarrow P$, on the (t, s) -plane be as in Lemma 3.2. We denote by z_1, z_2, \dots, z_s the generators of $\pi_1(S^3 \setminus S)$ arising from the Wirtinger presentation associated to the fixed projection of S (see for example [Ro]). The generators z_i are in one to one correspondence with the arcs of the projection between two consecutive under crossings. Moreover, every z_i is a conjugate of one of the free generators fixed earlier.

In Figure 2 we have indicated the Wirtinger generators by small arrows under the bands. The directions of the arrows are determined by the fixed orientations of the free generators $x_1, y_1, \dots, x_g, y_g$. Notice that these free generators can be chosen as a part of the Wirtinger generators corresponding to the hooks $\alpha_1, \hat{\alpha}_1, \dots, \alpha_{2g-1}, \hat{\alpha}_{2g}$, respectively.

Lemma 3.6. (The geometric rewriting) *Let $\gamma \subset S$ be a simple closed curve represented by the core of a band B of S , and let γ^ϵ ($\epsilon = \pm$) be one of the push off's of γ . Moreover, let $W = z_{i_1} \cdots z_{i_m}$ be a word representing γ^ϵ in terms of the Wirtinger generators of the projection, and let $W' = W'(x_i, y_j)$ be the word obtained from W by expressing each z_{i_r} in terms of the free generators. Then, there exists a projection*

$$p' : S \rightarrow P$$

which is obtained from p by isotopy, and such that every letter in W' is realized by an under crossing of B with one of the hooks above l .

Proof: Suppose that $\epsilon = +$. Assume first that B is flat. Then every z_{i_r} in W can be realized by an under crossing of B with another band or itself. We claim that the projection obtained in Lemma 3.4 has the desired properties.

To see that, let us begin with three Wirtinger generators z_i, z_j, z_k , around a crossing of the projection as show in Figure 2 (a). Then we have $z_k = z_i z_j z_i^{-1}$. Notice that γ^+ , which is drawn by the dotted arrow, picks up z_k at the under crossing in (a). After performing a *finger move* in (b), each of z_i, z_j, z_i^{-1} is realized by an under crossing. Thus the geometric equivalent of replacing each z_{i_j} , in $W = z_{i_1} \cdots z_{i_m}$, by its expression in terms of the free generators is to slide an under crossing of B until it reaches the appropriate hook. Now the desired conclusion follows easily from this observation.

If B is not flat, we first assume that the twists are all near one of the ends of B . Let the Wirtinger generator near that end of B be z_0 . Then $W = z_0^k z_{i_1} \cdots z_{i_m}$, and every z_{i_r} can be realized by an under crossing of B with another band or itself. The previous argument still works in this case for each z_{i_j} . For z_0^k , we may first move the twists up to a place around l and then replace the twists by a family of nested kinks, like in the last part of the proof of Lemma 3.4. \square

3.3. Lower central series and curves on surfaces. For a group G let $[G, G]$ denote the commutator subgroup of G . The lower central series $\{G^{(m)}\}_{m \in \mathbb{N}}$, of G is defined by $G^{(1)} = G$ and

$$G^{(m+1)} = [G^{(m)}, G]$$

for $m \geq 1$. We begin by recalling some commutator identities that will be useful to us later on. See [KMS].

Proposition 3.7. (Witt-Hall identities) *Let G be a group and let k, m and l be positive integers. Suppose that $x \in G^{(k)}$, $y \in G^{(m)}$ and $z \in G^{(l)}$. Then*

- a) $[G^{(k)}, G^{(m)}] \subset G^{(k+m)}$ or $xy \equiv yx \pmod{G^{(k+m)}}$
- b) $[x, zy] = [x, z] [x, y] [[y, x], z]$
- c) $[xy, z] = [y, z] [[z, y], x] [x, z]$
- d) $[x, [y, z]] [y, [z, x]] [z, [x, y]] \equiv 1 \pmod{G^{(k+l+m+1)}}$
- e) *If $g \equiv g' \pmod{G^{(k)}}$ and $y \in G^{(m)}$ then $[g, y] \equiv [g', y] \pmod{G^{(k+m)}}$ and $[y, g] \equiv [y, g'] \pmod{G^{(k+m)}}$.*

Let F be a free group of finite rank and let $\mathbb{A} = \{a_1, \dots, a_k\}$ be a set of (not necessarily free) generators of F . Let a be an element in F and let $W = W_a(\mathbb{A})$ be a word in a_1, \dots, a_k representing a . Think of W as given as a list of spots in which we may deposit letters $a_1^{\pm 1}, a_2^{\pm 1}, \dots, a_k^{\pm 1}$. Now let $\mathbb{C} = \mathbb{C}(W) = \{C_1, \dots, C_m\}$ be a collection of disjoint non-empty sets of spots (or letters) in W . Let us denote by $2^{\mathbb{C}}$ the set of all subsets of \mathbb{C} . Finally, for an element $C \in 2^{\mathbb{C}}$ we will denote by W_C the word obtained from W by substituting the letters in all sets contained in C by 1.

Definition 3.8. ([NS]) *The element $a \in F$ is called n -trivial, with respect to \mathbb{A} , if it has a word presentation $W = W_a(\mathbb{A})$ with the following property: There exist a collection of $n + 1$ disjoint non-empty sets of letters, say $\mathbb{C} =$*

$\{C_1, \dots, C_{n+1}\}$, in W such that W_C represents the trivial element for every non-empty $C \in 2^{\mathbb{C}}$.

We will say that $a \in F$ is n -trivial if it is n -trivial with respect to a set of generators. The following lemma shows that this definition depends neither on the word presentation nor the set of generators used.

Lemma 3.9. *If $a \in F$ is n -trivial with respect to a generating set \mathbb{A} , then it is n -trivial with respect to every generating set of F .*

Proof: Let $W = W_a(\mathbb{A}) = a_{i_1} a_{i_2} \dots a_{i_s}$ be a word for a satisfying the properties in Definition 2.8 and let \mathbb{A}' be another set of generators for F . By expressing each a_{i_j} as a word of elements in \mathbb{A}' we obtain a word $W' = W'_a(\mathbb{A}')$ which satisfies the requirements of n -triviality with respect to \mathbb{A}' . \square

Lemma 3.10. *If a lies in $F^{(n+1)}$, then it is n -trivial*

Proof: Observe that a basic commutator $[a, b] = aba^{-1}b^{-1}$ is 1-trivial by using $\mathbb{C} = \{\{a, a^{-1}\}, \{b, b^{-1}\}\}$, and induct on n . \square

Clearly, we do not change the n -triviality of a word by inserting a *canceling pair* xx^{-1} or $x^{-1}x$, where x is a generator. We will use the following definition to simplify the exposition.

Definition 3.11. *A simple commutator of length n is a word in the form of $[A, x^{\pm 1}]$ or $[x^{\pm 1}, A]$ where x is a generator and $A \in F^{(n-1)}$ is a simple commutator of length $n-1$. A simple quasi-commutator is a word obtained from a simple commutator by finitely many insertions of canceling pairs.*

By Proposition 3.7, any word representing an element in $F^{(n)}$ can be changed to a product of simple quasi-commutators of length $\geq n$ by finitely many insertions of canceling pairs. A simple quasi-commutator of length $> n$ is clearly n -trivial.

To continue, let S be a regular Seifert surface of a knot K . For a loop $\alpha \subset S^3 \setminus S$, we will denote by $[\alpha]$ its homotopy class in $\pi := \pi_1(S^3 \setminus S)$.

Suppose that $S, \gamma, B, p' : S \rightarrow P$ and $[\gamma^\epsilon] = W'(x_i, y_i) = W'$ are as in the statement of Lemma 3.12. Suppose δ is a sub-band of γ and $[\delta^\epsilon] = W''$ is a sub-word of W' . Assume that W'' represents an element in $\pi^{(n)}$.

Lemma 3.12. (The geometric realization) *There exists a projection $p_1 : S \rightarrow P$ with the following properties:*

- i) $p_1(S)$ is obtained from $p'(S)$ by a finite sequence of band Reidemeister moves of type II;*
- ii) B is in good position with respect to the new projection;*
- iii) the word $W^* = W^*(x_i, y_i)$ one reads out from δ (with respect to the new projection p'), by picking up one letter for each crossing of δ underneath the hooks, is a product of simple quasi-commutators of length $\geq n$.*

Proof: Since W'' represents an element in $\pi^{(n)}$, we may change W'' to a product of simple quasi-commutators by finitely many insertions of canceling pairs. Such an insertion of a canceling pair can be realized geometrically by a finger move (type II Reidemeister move). We will create a region in the projection plane to perform such a finger move. This region is a horizontal long strip below the line l and its intersection with $p'(S)$ consists of vertical straight flat bands. See Figure 4.

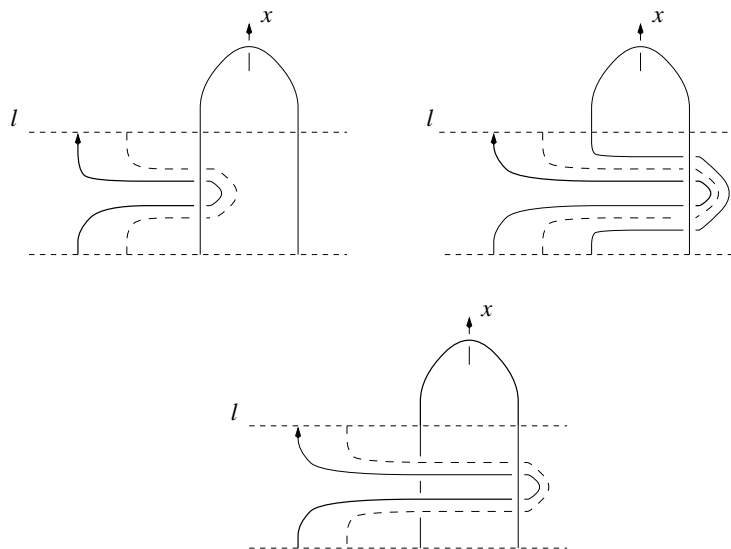

FIGURE 4. Realizing an insertion of $x^{-1}x$ or xx^{-1} by isotopy

As shown in Figure 4, there are two situations corresponding to insertions of $x^{-1}x$ or xx^{-1} . In one of the cases, we shall either let the finger go over one of the vertical flat bands connected to the x -hook (in the case that the x -hook does not belong to B) or push that vertical flat band along with the finger move (in the case that the x -hook belongs to B). Furthermore, if some vertical flat bands belonging to B block the way of the finger move, we will make more insertions by pushing these vertical flat bands along with the finger move. Finally, with all these done, we may easily modify the projection further to make B still in good position and ready to do the next insertion. \square

3.4. An example. In Figure 5, we show an example of a regular Seifert surface of genus one.

The cores of the bands A and B of the surface S have been drawn by the dashed, oriented curves γ_A and γ_B , respectively. The fundamental group $\pi := \pi_1(S^3 \setminus S)$ is freely generated by x and y . We have $[\gamma_A^+] \in \pi^{(3)}$, where γ_A^+ is the push-off of γ_A along the positive normal vector of the surface S

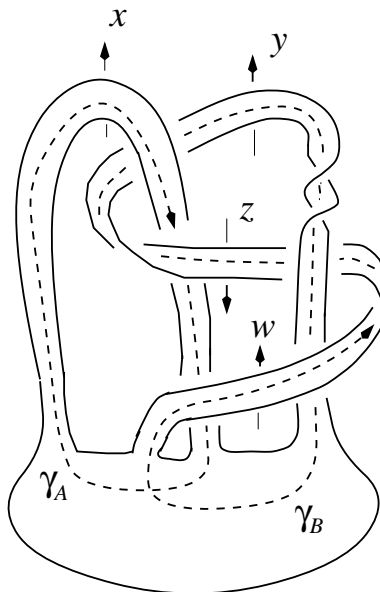
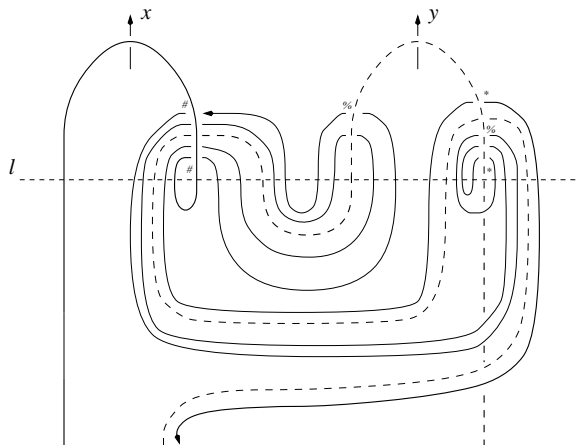

FIGURE 5. A 2-hyperbolic surface

pointing upwards the projection plane. In fact, from the Wirtinger presentation obtained from the given projection we have $[\gamma_A^+] = [zw^{-1}] = [[x, y], y^{-1}]$. Such a surface will be called *2-hyperbolic* in Definition 4.1.

FIGURE 6. The band A in good position

Now we modify the projection of S , so that A is in good position. The resulting projection is shown in Figure 6. Here we have only drawn the cores of the bands. The solid (dashed, resp.) arc corresponds to the band A (B , resp.) of Figure 6. The word we read out when traveling along

the solid arc, one letter for each crossing underneath the hooks, is exactly $W = [[x, y], y^{-1}]$.

Remark 3.13. There is an obvious collection \mathbb{C} of three sets of letters of W , so that W becomes a trivial word whenever we delete letters in a non-empty $C \in 2^{\mathbb{C}}$ from W . The projection of Figure 6 has the property that every letter in the word $W = [[x, y], y^{-1}]$ is realized by a band crossing. So we obtain a collection of sets of crossings, also denoted by \mathbb{C} . However, as the reader can verify, the image of γ_A on the surface S_C , obtained from S by switching the crossings in C , will not always be homotopically trivial in $S^3 \setminus S_C$.

4. COMMUTATORS AND VASSILIEV INVARIANTS

In this section we undertake the study of *regular* Seifert surfaces, whose complement looks, modulo the first $n + 1$ terms of the lower central series of its fundamental group, like the complement of a null-isotopy. Our main goal is to show that the existence of such a surface for a knot K forces its Vassiliev invariants of certain orders to vanish.

4.1. Definitions. Before we are able to state our main result in this section we need some notation and terminology. Let K be a knot in S^3 and let S be a Seifert surface of K , of genus g . Throughout this paper a *basis* of S will be a collection of $2g$ non-separating simple closed curves $\{\gamma_1, \beta_1, \dots, \gamma_g, \beta_g\}$ that represent a symplectic basis of $H_1(S)$. That is we have $\mathbb{I}(\gamma_i, \gamma_j) = \mathbb{I}(\beta_i, \beta_j) = \mathbb{I}(\beta_i, \gamma_j) = 0$, for $i \neq j$, and $\mathbb{I}(\gamma_i, \beta_i) = 1$, where \mathbb{I} denotes the intersection form on S . Each of the collections $\{\gamma_1, \dots, \gamma_g\}$ and $\{\beta_1, \dots, \beta_g\}$ will be called a *half basis*.

To continue let $\pi := \pi_1(S^3 \setminus S)$. For a basis $\mathbb{B} = \{\gamma_1, \beta_1, \dots, \gamma_g, \beta_g\}$ of $H_1(S)$ let $\mathbb{B}^* = \{x_1, y_1, \dots, x_g, y_g\}$ denote elements in π representing the dual basis of $H_1(S^3 \setminus S)$.

For a subset \mathbb{A} of \mathbb{B} , let $\mathbb{G}_{\mathbb{A}}$ denote the normal subgroup of π generated by the subset of \mathbb{B}^* corresponding to \mathbb{A} . Moreover, we will denote by $\pi_{\mathbb{A}}$ (resp. $\phi_{\mathbb{A}}$) the quotient $\pi/\mathbb{G}_{\mathbb{A}}$ (resp. the quotient homomorphism $\pi \rightarrow \pi/\mathbb{G}_{\mathbb{A}}$). Finally, $\pi_{\mathbb{A}}^{(m)}$ will denote the m -th term of the lower central series of $\pi_{\mathbb{A}}$. For the following definition it is convenient to allow \mathbb{A} to be the empty set and have $\pi_{\mathbb{A}} = \pi$.

Definition 4.1. Let $n \in \mathbb{N}$. A regular Seifert surface S is called *n-hyperbolic*, if it has a half basis \mathbb{A} represented by circles in a regular spine Σ with the following property: There is an ordering, $\gamma_1, \dots, \gamma_g$, of the elements in \mathbb{A} such that either $\phi_{\mathbb{A}_{i-1}}([\gamma_i^+])$ or $\phi_{\mathbb{A}_{i-1}}([\gamma_i^-])$ lies in $\pi_{\mathbb{A}_{i-1}}^{(n+1)}$. Here $\mathbb{A}_k = \{x_1, y_1, \dots, x_k, y_k\}$ for $k = 1, \dots, g$ and \mathbb{A}_0 is the empty set. The boundary of such a surface will be called an *n-hyperbolic knot*.

In order to state our main result in this section we need some notation. For $m \in \mathbb{N}$, let $q(m)$ be the quotient of division of m by six (that is $m = 6q(m) + r_1$, $0 \leq r_1 \leq 5$). Let the notation be as in Definition 4.1. For $i = 1, \dots, g$, let x_i denote the free generator of π that is dual to $[\gamma_i]$. Let l_i denote the number of distinct elements in $\{x_1, y_1, \dots, x_g, y_g\}$, that are different than x_i and whose images under $\phi_{\mathbb{A}_{i-1}}$ appear in a (reduced) word, say W_i , representing $\phi_{\mathbb{A}_i}([\gamma_i^+])$ or $\phi_{\mathbb{A}_i}([\gamma_i^-])$. Write W_i as a product, $W_i = W_i^1 \dots W_i^{s_i}$, of elements in $\pi_{\mathbb{A}_{i-1}}^{(n+1)}$ and partition the set $\{W_i^1, \dots, W_i^{s_i}\}$ into disjoint sets, say $\mathbb{W}_i^1, \dots, \mathbb{W}_i^{t_i}$ such that: i) $k_i^1 + \dots + k_i^{t_i} = l_i$, where k_i^j is the number of distinct elements in \mathbb{A}_i involved in \mathbb{W}_i^j and ii) for $a \neq b$, the sets of elements from \mathbb{A}_i appearing \mathbb{W}_i^a and \mathbb{W}_i^b are disjoint. Let

$$k_i = \min\{k_i^1, \dots, k_i^{t_i}\}.$$

and let

$$q_{\gamma_i} := q(n+1) \quad \text{if } n < 6k,$$

and

$$q_{\gamma_i} := k_i + \left\lceil \log_2 \frac{n+1-6k_i}{6} \right\rceil, \quad \text{if } n \geq 6k.$$

Notice that

$$q(n+1) > \frac{n+1}{6} - 1 = \frac{n-5}{6} > \log_2\left(\frac{n-5}{6}\right).$$

Also, since $ab \geq a+b$ if $a, b > 1$, we have

$$k_i + \log_2\left(\frac{n+1-6k_i}{6}\right) > \log_2 k_i + \log_2\left(\frac{n+1-6k_i}{6}\right) > \log_2\left(\frac{n+1}{36}\right).$$

Thus, for $n > 5$, we have

$$q_{\gamma_i} > \log_2\left(\frac{n-5}{72}\right).$$

We define $l(n)$ by

$$l(n, S) = \min\{q_{\gamma_1} - 1, \dots, q_{\gamma_g} - 1\},$$

and

$$l(n) = \min\{l(n, S) \mid S \text{ is } n\text{-hyperbolic}\}.$$

We can now state our main result in this section, which is:

Theorem 4.2. *If K is n -hyperbolic, for some $n \in \mathbb{N}$, then K is at least $l(n)$ -trivial. Thus, all the Vassiliev invariants of K of orders $\leq l(n)$ vanish.*

From our analysis above, we see that $l(n) > \log_2\left(\frac{n-5}{144}\right)$ and in particular $\lim_{n \rightarrow \infty} l(n) = \infty$. Thus, an immediate Corollary of Theorem 4.2 is:

Corollary 4.3. *If K is n -hyperbolic, for all $n \in \mathbb{N}$, then all its Vassiliev invariants vanish.*

Assume that S is in disc-handle form as described in Lemma 3.2 and that the cores of the bands form a symplectic basis of $H_1(S)$. Moreover, assume that the curves $\gamma_1, \dots, \gamma_g$, of Definition 4.1 can be realized by half of these cores. Let β_1, \dots, β_g denote the cores of the other half bands and let $D = D(K)$ denote the knot diagram of K , induced by our projection of the surface. Also we may assume that the dual basis $\{x_1, y_1, \dots, x_g, y_g\}$ is represented by free generators of π , as before the statement of Lemma 3.4.

To continue with our notation, let C be a collection of band crossings on the projection of S . We denote by S_C (resp. D_C) the Seifert surface (resp. knot diagram) obtained from S (resp. D) by switching all crossings in C , simultaneously. For a simple curve $\gamma \subset S$ (or an arc $\delta \subset \gamma$), we will denote by γ_C (or δ_C) the image of γ (or δ) on S_C .

Let γ be the core of a band B in good position and suppose that it is decomposed into a union of sub-arcs $\eta \cup \delta$ with disjoint interiors, such that the word, say W , represented by δ^+ (or δ^-) in $\pi := \pi_1(S^3 \setminus S)$ lies in $\pi^{(m+1)}$. Let x be the generator of π corresponding to B and let l denote the number of distinct free generators, different than x , appearing in W . Write W as a product, $W = W_1 \dots W_s$, of commutators in $\pi^{(n+1)}$ and partition the set $\{W_1, \dots, W_s\}$ into disjoint sets, say $\mathbb{W}_1, \dots, \mathbb{W}_t$ such that: i) $k_1 + \dots + k_t = l$, where k_j is the number of distinct generators involved in \mathbb{W}_j and ii) for $a \neq b$, the sets of generators appearing \mathbb{W}_a and \mathbb{W}_b are disjoint. Let $k = \min\{k_1, \dots, k_t\}$. We define

$$q_\delta := q(n+1) \quad \text{if } n < 6k,$$

and

$$q_\delta := k + \left\lceil \log_2 \left(\frac{n+1-6k}{6} \right) \right\rceil \quad \text{if } n \geq 6k.$$

The proof of Theorem 4.2 will be seen to follow from the following Proposition.

Proposition 4.4. *Let γ be the core of a band B in good position and suppose that it is decomposed into a union of sub-arcs $\eta \cup \delta$, such that the word represented by δ^+ (or δ^-) in $\pi := \pi_1(S^3 \setminus S)$ lies in $\pi^{(m+1)}$. Suppose that the word, in the generators $x_1, y_2, \dots, x_g, y_g$ of π fixed earlier, represented by η^+ (or η^-) is the empty one.*

Let K' be the boundary of the surface obtained from S by replacing the sub-band of B corresponding to δ with a straight flat ribbon segment δ^ , connecting the endpoints of δ and above (resp. below) the remaining diagram. Then K and K' are at least l_δ -equivalent, where $l_\delta := q_\delta - 1$.*

The proof of Proposition 4.4 will be divided into several steps, and occupies all of §3. Without loss of generality we will work with δ^+ and γ^+ .

In the course of the proof we will see that we may choose the collection of sets of crossings \mathbb{C} , required in the definition of l_δ -equivalence, to be band crossings in a projection of S . Moreover, for every non-empty $C \in 2^{\mathbb{C}}$, δ_C will be shown to be isotopic to a straight arc, say δ^* , as in the statement above. Here $2^{\mathbb{C}}$ is the set of all subsets of \mathbb{C} .

Proof: [of Theorem 4.2 assuming Proposition 4.4]. The proof will be by induction on the genus g of the surface S . If $g = 0$ then K is the trivial knot and there is nothing to prove. For $i = 1, \dots, g$, let A_i denote the band of S whose core corresponds to γ_i , and let B_i be the dual band.

By Definition 4.1 we have a band A_1 , such that the core γ satisfies the assumption of Proposition 4.4. We may decompose γ into a union of sub-arcs $\eta \cup \delta$ with disjoint interiors such that the word represented by δ^+ (resp. η^+) in $\pi := \pi_1(S^3 \setminus S)$ lies in $\pi^{(n+1)}$ (resp. is the empty word). Let K' be a knot obtained from K by replacing the sub-band of B corresponding to δ with a straight flat ribbon segment δ^* , connecting the endpoints of δ and above the remaining diagram, and let S' be the corresponding surface obtained from S . We will also denote the core of δ^* by δ^* .

By Proposition 4.4, K and K' are l_δ -equivalent. One can see that K' is n -hyperbolic, and it bounds an n -hyperbolic surface of genus strictly less than g .

Obviously, there is a circle on S' with δ^* as a sub-arc which bounds a disk D in $S^3 \setminus S'$. A surgery on S' using D changes S' to S'' with $\partial S'' = K'$, and we conclude that S'' is an n -hyperbolic regular Seifert surface with genus $g - 1$. Thus, inductively, K' , and hence K , is at least $l(n)$ -trivial. \square

4.2. Nice arcs and simple commutators. In this paragraph we begin the study of the geometric combinatorics of arcs in good position and prove a few auxiliary lemmas required for the proof of Proposition 4.4. At the same time we also describe our strategy of the proof of Proposition 4.4.

Throughout the rest of section three, we will adapt the convention that the endpoints of δ or of any subarc $\tilde{\delta} \subset \delta$ representing a word in $\pi^{(m+1)}$, lie on the line l associated to our fixed projection. Let $W = c_1 \dots c_r$ be a word expressing δ^+ as a product of simple (quasi-)commutators of length $m + 1$, and let $p_1(S)$ be a projection of S , as in Lemma 3.12. Then, each letter in W is represented by a band crossing in the projection. Now, let $\mathbb{C} = \{C_1, \dots, C_{m+1}\}$ be disjoint sets of letters obtained by applying Lemma 3.9 to the word W , so that W becomes a trivial word whenever we delete letters in a non-empty $C \in 2^{\mathbb{C}}$ from W (the resulting word is denoted by W_C).

Let y be a free generator appearing in W . We will say that the letters $\{y, y^{-1}\}$ constitute a *canceling pair*, if there is some $C \in 2^{\mathbb{C}}$ such that the word W_C can be reduced to the identity, in the free group π , by a series of deletions in which y and y^{-1} cancel with each other.

Ideally, we would like to be able to say that for every $C \in 2^{\mathbb{C}}$ the arc δ_C (obtained from δ by switching all crossings corresponding to C) is isotopic in $S^3 \setminus S_C$ to a straight segment connecting the end points of δ and above the remaining diagram. As remarked in 3.13, though, this may not always be the case. In other words not all sets of letters \mathbb{C} , that come from Lemma 3.9, will be suitable for geometric m -triviality. This observation leads us to the following definition.

Definition 4.5. *Let S , B and δ be as in the statement of Proposition 4.4 and let $\tilde{\delta} \subset \delta$ be a subarc that represents a word W in $\pi^{(m+1)}$. Furthermore let δ^* be an embedded segment connecting the endpoints of $\tilde{\delta}$ and such that $\partial\delta^* \subset l$ and the interior of δ^* lies above the projection of S on the projection plane.*

1) *We will say that $\tilde{\delta}$ is quasi-nice if there exists a segment δ^* as above and such that either the interiors of δ^* and $\tilde{\delta}$ are disjoint, or $\tilde{\delta} = \delta^*$ and δ^* is the hook of the band B . Furthermore, if the interiors of δ^* and $\tilde{\delta}$ are disjoint then δ^* should not separate any set of crossings corresponding to a canceling pair in W on any of the hooks of the projection.*

2) *Let δ be a quasi-nice arc, and let δ^* be as in 1). Moreover, let S' denote the surface $S \cup n(\delta^*)$, where $n(\delta^*)$ is a flat ribbon neighborhood of δ^* . We will say that δ is k -nice, for some $k \leq m+1$, if there exists a collection \mathbb{C} of k disjoint sets of band crossings on $\tilde{\delta}$, such that for every non-empty $C \in 2^{\mathbb{C}}$, the loop $(\delta^* \cup \tilde{\delta}_C)^+$ is homotopically trivial in $S^3 \setminus S'_C$, where $S'_C = S_C \cup n(\delta^*)$. We will say that every $C \in 2^{\mathbb{C}}$ trivializes $\tilde{\delta}$ geometrically.*

Notice that the arc in the example on the left side of Figure 7 is both 2-nice and quasi-nice while the one on the right side is not. In fact, one can see that all embedded arcs in good position representing simple 2-commutators are 2-nice.

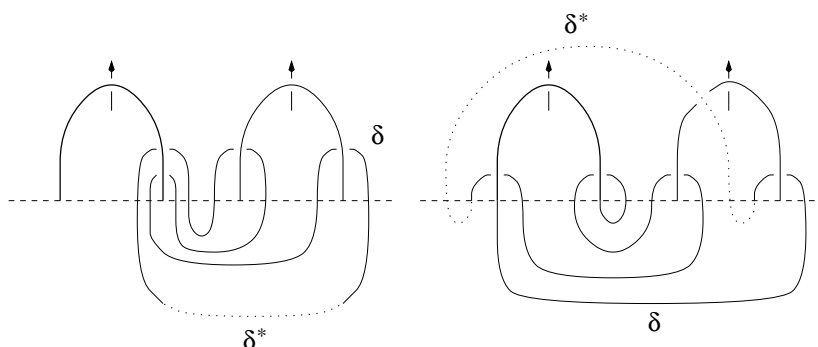

FIGURE 7. Nice arcs representing simple 2-commutators

Lemma 4.6. *Let δ be a subarc of the core of a band B , in a projection of a regular surface S . Let δ^* be a straight segment, connecting the endpoints of δ and let S' denote the surface $S \cup n(\delta^*)$. Suppose that the loop $(\delta^* \cup \delta)^+$ is homotopically trivial in $S^3 \setminus S'$. Then $n(\delta)$ can be isotoped onto $n(\delta^*)$ in $S^3 \setminus S$ relative to the endpoints.*

Proof: Since $\delta^* \cup \delta \subset S'$ is an embedded loop, by Dehn's Lemma (see for example [He] or [Ro]) we conclude that it bounds an embedded disc in $S^3 \setminus S'$. Then the claim follows easily. \square

Corollary 4.7. *Let γ and δ as in the statement of Proposition 4.4. Assume that δ is an q_δ -nice arc. Then the conclusion of the Proposition is true for δ .*

For the rest of this subsection we will focus on projections of arcs, in *good position*, that represent simple quasi-commutators. We will analyze the geometric combinatorics of such projections. This analysis will be crucial, in the next paragraphs, in showing that an arc δ as in Proposition 4.4 is q_δ -nice.

Let δ_1 be a subarc of δ presenting a simple quasi-commutator of length m , say c . Moreover, let δ_2 be another subarc of δ presenting a simple quasi-commutator equivalent to c or c^{-1} . We may change the orientation of δ_2 if necessary so that it presents a simple quasi-commutator equivalent to c . Then we may speak of the initial (resp. terminal) point $p_{1,2}$ (resp. $q_{1,2}$) of $\delta_{1,2}$; recall these points all lie on the line l .

Definition 4.8. *Let $\hat{\delta}_1$ (resp. $\hat{\delta}_2$) be the segment on l going from p_1 to p_2 (resp. q_1 to q_2). We say that δ_1 and δ_2 are parallel if the following are true: i) At most one hook has its end points on $\hat{\delta}_1$ or $\hat{\delta}_2$ and both of its end points can be on only one of $\hat{\delta}_{1,2}$; ii) If a hook has exactly one point on some $\hat{\delta}_j$, say on $\hat{\delta}_1$, then $\hat{\delta}_1$ doesn't intersect the interior of $\delta_{1,2}$. iii) We have either $\hat{\delta}_1 \cap \hat{\delta}_2 = \emptyset$ or $\hat{\delta}_1 \subset \hat{\delta}_2$; iv) If $\hat{\delta}_{1,2}$ are drawn disjoint and above the surface S , the diagram $\delta_1 \cup \hat{\delta}_1 \cup \delta_2 \cup \hat{\delta}_2$ can be changed to an embedding by type II Reidemeister moves.*

The reader may use Figure 8 to understand Definition 4.8. It should not be hard to locate the arcs $\hat{\delta}_{1,2}$ in each case in Figure 8.

In the first two pictures, the straight arcs $\hat{\delta}_{1,2}$ have no crossings with $\delta_{1,2}$. Crossings between $\hat{\delta}_{1,2}$ and $\delta_{1,2}$ removable by type II Reidemeister moves are allowed to accommodate the modification of $\delta_{1,2}$ in Lemma 3.12. For example, in the last two pictures of Figure 8 one of $\hat{\delta}_{1,2} \subset l$ intersects both of $\delta_{1,2}$.

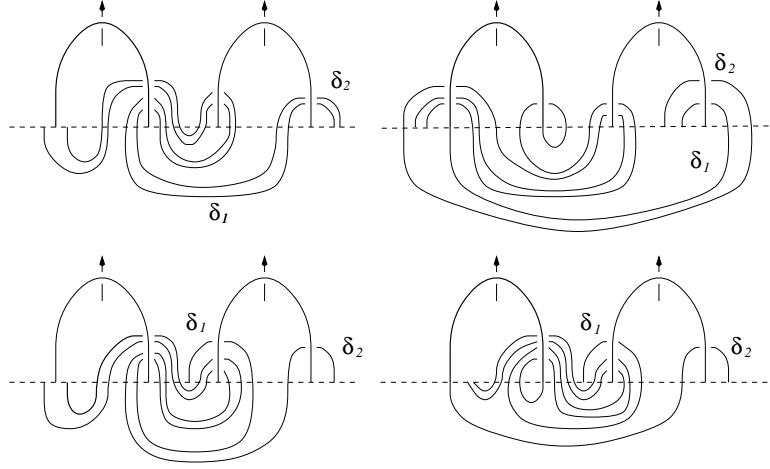

FIGURE 8. Various kinds of parallel arcs

Lemma 4.9. *Assume that the setting is as in the statement of Proposition 4.4. Let c_1 and c_2 be equivalent simple quasi-commutators presented by subarcs $\delta_{1,2}$ of δ respectively, and let y be one of the free generators associated to the hooks of our fixed projection. Moreover, assume that $\delta_{1,2}$ are parts of a subarc ζ of δ presenting a simple quasi-commutator $W = c_1 y c_2^{-1} y^{-1}$. Then δ_1 and δ_2 are parallel.*

Proof: By abusing the notation, we denote $\delta_1 = \tau_1 x \mu_1 x^{-1}$ and $\delta_2 = \tau_2 x \mu_2 x^{-1}$ where $\tau_1, \tau_2, \mu_1^{-1}, \mu_2^{-1}$ represent simple quasi-commutators that are equivalent. Furthermore, $\zeta = \delta_1 y \delta_2^{-1} y^{-1}$. For a subarc ν , up to symmetries, there are four possible ways for both of its endpoints to reach a certain z -hook so that $z \nu z^{-1}$ is presented by an arc in good position. See Figure 9, where the arc ν may run through the z -hook. We will call the pair of under crossings $\{z, z^{-1}\}$ a *canceling pair*. Now let us consider the relative positions of τ_1, τ_2, μ_1 and μ_2 . Inductively, τ_i and μ_i^{-1} are parallel, for $i = 1, 2$. If $x \mu_1 x^{-1}$ is of type (I) in Figure 9, since τ_1 and μ_1^{-1} are parallel, τ_1 has to go the way indicated in Figure 10 (a).

If $x \mu_2 x^{-1}$ is also of type (I), there are two cases to consider. One case is to have the canceling pairs $\{x, x^{-1}\}$ in $x \mu_1 x^{-1}$ and $x \mu_2 x^{-1}$ both going underneath the x -hook at the left side, and the other case is to have them going underneath the x -hook at different sides. In the first case, in order to read the same word from τ_1 and τ_2 as well as from μ_1 and μ_2 , $\tau_1 x \mu_1 x^{-1}$ and $\tau_2 x \mu_2 x^{-1}$ has to fit like in Figure 10 (b). This implies that δ_1 and δ_2 are parallel. In the second case (see Figure 10 (c)), in order that δ_i be parts of the arc $\zeta = \delta_1 y \delta_2^{-1} y^{-1}$, they have to go to reach the same y -hook.

But then we will not be able to read the same word through τ_1 and τ_2 . This shows that if $x \mu_1 x^{-1}$ and $x \mu_2 x^{-1}$ are both of type (I), δ_1 and δ_2 are

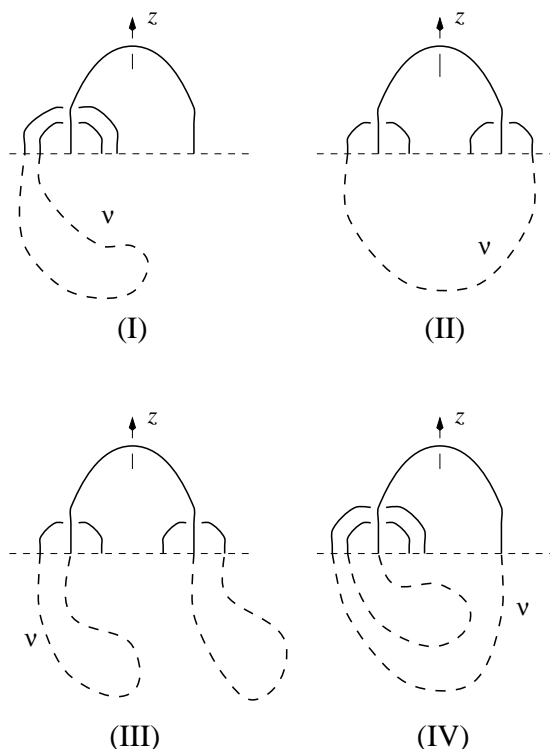
FIGURE 9. Types of arcs presenting $z\nu z^{-1}$

parallel. There are many other cases which can be checked one by one in the same way as in Figure 10. The details are left to the patient reader. \square

So far we have been considering the projection of our surface on a plane P inside $\mathbb{R}^3 = P \times \mathbb{R}$. To continue, let us pass to the compactifications of \mathbb{R}^3 and P . We obtain a 2-sphere S_P^2 inside S^3 , and assume that our projection in Proposition 3.3 lies on S_P^2 . We may identify the image of l with the equator of S_P^2 , and the images of H_+ and H_- with the upper and lower hemisphere. We will interchange between P and S_P^2 whenever convenient.

Remark 4.10. Let δ, B be as in the statement of Proposition 4.4 and let x_0 denote the free generator of $\pi_1(S^3 \setminus S)$ corresponding to B . Suppose δ_1 and δ_2 are parallel subarcs of δ and let $\hat{\delta}_{1,2}$ be as in Definition 4.8. We further assume that the crossings between $\hat{\delta}_{1,2}$ and $\delta_{1,2}$ have been removed by isotopy. Let y be a free generator of $\pi := \pi_1(S^3 \setminus S)$. We assume that both δ_1 and δ_2 are sub-arcs of an arc $\zeta \subset \delta$ presenting $[c^{\pm 1}, y^{\pm 1}]$ (recall that $\delta_{1,2}$ present $c^{\pm 1}$). Then ζ is a union $\delta_1 \cup \tau_1 \cup \delta_2 \cup \tau_2$, where $\tau_{1,2}$ are segments each going once underneath the y -hook. One point of ζ is the same as one endpoint of one of $\delta_{1,2}$, say δ_2 . Let $\bar{\delta} := \delta \setminus (\delta_1 \cup \delta_2)$. By the properties of good position we see that in order for one of $\delta_{1,2}$, say δ_1 , not to be embedded

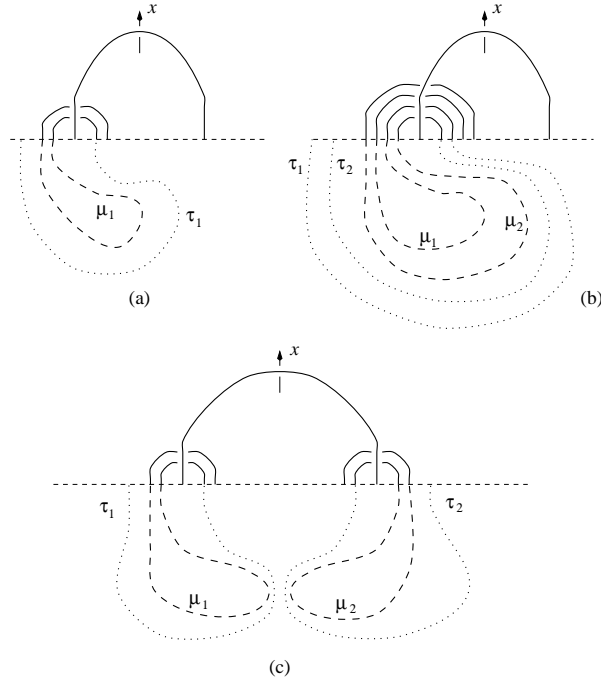

FIGURE 10. The case when both $x\mu_1x^{-1}$ and $x\mu_2x^{-1}$ are of type (I)

on the projection plane it must run through the hook part of B , and the word representing δ_1 must involve x_0 . Moreover, good position imposes a set of restrictions on the relative positions of $\delta_{1,2}$ and the various subarcs of $\bar{\delta}$. Below we summarize the main features of the relative positions of $\delta_{1,2}$ and the various subarcs of $\bar{\delta}$; these features will be useful to us in the rest of the paper. We will mainly focus on the case that $\delta_{1,2}$ are embedded; the case of non-embedded arcs is briefly discussed in part b) of this Remark.

a) Suppose that $\delta_{1,2}$ are embedded on the projection plane P . Then the loop $\delta_1 \cup \hat{\delta}_2 \cup \delta_2 \cup \hat{\delta}_1$ separates S_P^2 into two discs, D_1 and D_2 . The intersections $D_{1,2} \cap \bar{\delta}$ consist of finitely many arcs. With the exception of at most one these arcs are embedded. One can see (see the two pictures on the left side of Figure 8) that the interiors of $\tau_{1,2}$ are disjoint from that of exactly one of $D_{1,2}$, say D_1 , and they lie in the interior of the other. We will call D_1 (resp. D_2) the *finite* (resp. *infinite*) disc corresponding to the pair $\delta_{1,2}$. Using the properties of good position one can see that for each component θ of $D_1 \cap \bar{\delta}$, which lies on a subarc of $\bar{\delta}$ representing a simple quasi-commutator, one of the following is true:

(a₁) Both the endpoints of θ lie on $\hat{\delta}_2$ and θ can be pushed in the infinite disc D_2 after isotopy, or it represents a word w , such that the following is true: None of the letters appearing in the reduced form of w appears in the

underlying commutator of c . Moreover for each free generator x appearing in w , $C^{\pm 1}$ contains inserted pairs $x^{\pm 1}x^{\mp 1}$. To see these claims, first notice that if one of the generators, say z , appears in the underlying commutator of c then the intersection of D_1 and the z -hook consists of two (not necessarily disjoint) arcs, say $\theta_{1,2}$, such that one point of $\partial(\theta_{1,2})$ is on δ_1 and the other on δ_2 . Moreover, both the endpoints of the z -hook lie outside D_1 in the infinite disc. Now a subarc of $\bar{\delta}$ in D_1 has the choice of either hooking with z in exactly the same fashion as $\delta_{1,2}$, or “push” $\theta_{1,2}$ by a finger move as indicated in Figure 4, and hook with some $x \neq z^{\pm 1}$. In order for the second possibility to occur, at least one of the endpoints of the x -hook must lie inside D ; by our discussion above this will not happen if x has already appeared in the underlying commutator of c . The rest of the claim follows from the fact that the “top” of the x -hook must lie outside D_1 .

(a_2) One endpoint of θ is on $\hat{\delta}_1$ and the other on $\hat{\delta}_2$. Moreover, θ either represents $c^{\pm 1}$ or the trivial word or it represents a w , as in case (a_1) above.

(a_3) θ is a subarc of the hook corresponding to the band B , and it has one endpoint on δ_1 and the other on δ_2 or one point on δ_i and the other on $\hat{\delta}_j$ ($i, j = 1, 2$). Furthermore, if θ has one endpoint on δ_i and the other on $\hat{\delta}_j$ then i) the underlying commutator of c does not involve $x_0^{\pm 1}$; and ii) both endpoints of the x_0 -hook lie inside D_1 .

(a_4) One of $\delta_{1,2}$, say δ_1 , runs through the hook part of B and θ has one point on δ_1 and the other on $\hat{\delta}_j$ ($i, j = 1, 2$). Moreover, we have: i) The arc θ represents $wx_0^{\pm 1}$ where either $w = c^{\pm 1}$ or none of the letters appearing in there reduced form of w appears in the underlying commutator of c ; ii) the underlying commutator of c does not involve $x_0^{\pm 1}$; iii) if e is a simple quasi-commutator represented by a subarc $\tilde{\delta}$ such that $\delta_{1,2} \subset \tilde{\delta}$, then the underlying commutator of e does not involve $x_0^{\pm 1}$ (see also Lemma 3.12 (a)).

b) Recall that x_0 is the free generator of π corresponding to B . Suppose that δ_1 is non-embedded. Then δ_1 to run through the hook of B and the word representing δ_1 must involve x_0 .

(b_1) It follows from the properties of good position that any subarc of $\theta \subset \delta$ that has its endpoints on different $\hat{\delta}_i$ has to represent $c^{\pm 1}$.

Lemma 4.11. *Let the setting be again as in the statement of Proposition 4.4, and let δ_1 be a subarc of δ representing a simple (quasi-)commutator. Moreover let h_0 denote the hook part of the band B . We can connect the endpoints of δ_1 by an arc δ_1^* , which is embedded on the projection plane and such that: i) δ_1^* lies on the top of the projection $p_1(S)$; ii) the boundary $\partial(\delta_1^*)$ lies on the line l ; and iii) either $\delta_1^* = h_0$ or the interiors of δ_1^* and δ_1 are disjoint and δ_1^* goes over at most one hook at most once.*

Proof: Suppose that δ_1 represents $W = [c, y^{\pm 1}]$ and let $\delta_1^{1,2}$ be the subarcs of δ_1 representing $c^{\pm 1}$ in W . By Lemma 4.9 $\delta_1^{1,2}$ are parallel; let $\hat{\delta}_1^{1,2}$ be the arcs of Definition 4.8 connecting the endpoints of $\delta_1^{1,2}$. Recall that there is at most one hook, say corresponding to a generator z , that can have its endpoints on $\delta_1^{1,2}$. If $z = y$ then, using good position, we see that there is an arc δ_1^* as claimed above such that either $\delta_1^* = h_0$ or it intersects at most the y -hook in at most one point. If $z \neq y$ then we can find an arc α satisfying i) and ii) above and such that either $\alpha = h_0$ or α intersects the y -hook in at most one point and the intersections of α with the other hooks can be removed by isotopying α , relatively its endpoints. Thus the existence of δ_1^* follows again. \square

Definition 4.12. *An arc δ_1 representing a simple (quasi-)commutator will be called good if the arc δ_1^* of Lemma 4.11, connecting the endpoints of the δ_1 , doesn't separate any canceling pair of crossings in δ_1 .*

The reader can see that the arc in the picture of the left side of Figure 7 is good while the one on the right is not good.

4.3. Outline of the proof of Proposition 4.4. In Definition 4.5, we defined the notions of quasi-niceness and k -niceness. By definition, a k -nice arc is quasi-nice. We will, in fact, show that the two notions are equivalent. More precisely, we show in Lemma 4.22 that a quasi-nice arc δ is q_δ -nice. This, in turn, implies Proposition 4.4. To see this last claim, notice that the arc δ in the statement of 4.4 is quasi-nice. Indeed, since the arc η in the statement of 4.4 represents the empty word in π , good position and the convention about the endpoints of δ made in the beginning of §4.2 assure the following: Either the interior of η lies below l (and above the projection of $S \setminus n(\eta)$) and it is disjoint from that of δ or η is the hook part of B . In both cases we choose $\delta^* = \eta$.

To continue, notice that a good arc is by definition quasi-nice. The notion of a *good* arc is useful in organizing and studying the various simple quasi-commutator pieces of the arc δ in 4.4. In Lemma 4.16 we show that if an arc $\tilde{\delta}$ is good then it is $q_{\tilde{\delta}}$ -nice and in Lemma 4.20 we show that if $\tilde{\delta}$ is a product of good arcs then it is $q_{\tilde{\delta}}$ -nice. In both cases we exploit good position to estimate the number of “bad” crossings along $\tilde{\delta}$, that are suitable for algebraic triviality but may fail for geometric triviality. All these are done in §4.4 and §4.5.

In §4.6 we begin with the observation that if $\tilde{\delta}$ is a product of arcs $\theta_1, \dots, \theta_s$ such that θ_i is q_{θ_i} -nice then $\tilde{\delta}$ is $q_{\tilde{\delta}}$ -nice (see Lemma 4.21). Finally, Lemma 4.22 is proven by induction on the number of “bad” subarcs that δ contains.

4.4. Bad sets and good arcs. In this subsection we continue our study of arcs in good position that represent simple quasi-commutators. Our goal, is to show that a good arc δ representing a simple quasi-commutator is q_δ -nice (see Lemma 4.16).

Let $W = [\dots[[y_1, y_2], y_3], \dots, y_{m+1}]$ be a simple (quasi-) commutator represented by an arc δ of the band B in good position. Suppose that the subarc of δ representing $W_1 = [\dots[[y_1, y_2], y_3], \dots, y_i]$, for some $i = 1, \dots, m+1$, runs through the hook part of B , at the stage that it realizes the crossings corresponding to y_i . The canceling pair corresponding to $\{y_i, y_i^{-1}\}$ will be called *the special canceling pair* of W .

Lemma 4.13. *Let $W = [\dots[[y_1, y_2], y_3], \dots, y_{m+1}]$ be a simple (quasi-) commutator represented by an arc δ of the band B in good position, and let x_0 be the free generator of π corresponding to the hook of B .*

a) *Suppose that, for some $i = 1, \dots, m+1$, one of the canceling pairs $\{y_i, y_i^{-1}\}$ is the special canceling pair. Then, we have $y_j \neq x_0^{\pm 1}$ for all $i < j \leq m+1$.*

b) *Let z be any free generator of π corresponding to one of the hooks of our projection. Then, at most two successive y_i 's can be equal to $z^{\pm 1}$.*

Proof: a) For $j > i$ let $c = [\dots[[y_1, y_2], y_3], \dots, y_{j-1}]$ and let $\delta_{1,2}$ be the arcs representing $c^{\pm 1}$ in $[c, y_j]$. By Lemma 4.9, $\delta_{1,2}$ are parallel. Let $\hat{\delta}_{1,2}$ be arcs satisfying Definition 4.8. Notice that the x_0 -hook can not have just one of its endpoints on $\hat{\delta}_{1,2}$. For, if the x_0 -hook had one endpoint on, say, $\hat{\delta}_1$, then $\hat{\delta}_1$ would intersect the interior of $\delta_{1,2}$. Now easy drawings will convince us that we can not form $W_1 = [c, x_0^{\pm 1}]$ without allowing the arc representing it to have self intersections below the line l associated to our projection. But this would violate the requirements of good position.

b) By symmetry we may assume that $W = [\dots, [d^{\pm 1}, z^{\pm 1}], y_j, \dots, y_{m+1}]$, where d is a simple (quasi-)commutator of length $< m$. A moment's thought will convince us that it is enough to prove the following: For a quasi-commutator $[\dots, [c^{\pm 1}, z^{\pm 1}], y_i, \dots, y_{m+1}]$, such that $z^{\pm 1}$ has already appeared in c , we have either $y_i \neq z^{\pm 1}$ or $y_{i+1} \neq z^{\pm 1}$. Furthermore, if the last letter in c is $z^{\pm 1}$, then $y_i \neq z^{\pm 1}$.

Let $\tilde{\delta}$ be the subarc of δ representing $[c^{\pm 1}, z^{\pm 1}]$, and let $\delta_{1,2}$ be the subarcs of $\tilde{\delta}$ representing $c^{\pm 1}$. By Lemma 4.9, $\delta_{1,2}$ are parallel. Let $\hat{\delta}_{1,2}$ be as in Definition 4.8.

Since we assumed that $z^{\pm 1}$ has already appeared in c , the intersection $\delta_{1,2} \cap H_+$ contains a collection of disjoint arcs $\{A_i\}$, each passing once under the z -hook, and with their endpoints on the line l . Let $A_{1,2}$ denote the innermost of the A_i 's corresponding to the left and right endpoint of the z -hook, respectively. Let $\alpha_{1,2}$ denote the segments of l connecting the endpoints of $A_{1,2}$, respectively. Our convention is that if $\{A_i\}$ contains no components that pass under the z -hook near one of its endpoints, say the right one, then

A_2 will be the outermost arc corresponding to the left endpoint. Thus, in this case, α_2 passes through infinity.

By good position and Definition 4.8, it follows that both of the endpoints of at least one of $\hat{\delta}_{1,2}$ must lie on α_1 or α_2 . There are three possibilities:

- (i) The endpoints of both $\hat{\delta}_{1,2}$ lie on the same $\alpha_{1,2}$, say on α_1 ;
- (ii) The endpoints of $\hat{\delta}_{1,2}$ lie on different $\alpha_{1,2}$;
- (iii) The endpoints of one of $\hat{\delta}_{1,2}$ lie outside the endpoints of $\alpha_{1,2}$.

Suppose we are in (i). Notice that both the endpoints of the arc $\tilde{\delta}$ must also lie on α_1 . By Definition 4.8 we see that both of the endpoints of any arc parallel to $\tilde{\delta}$ must also lie on α_1 . There are two possibilities for the relative positions of $\hat{\delta}_{1,2}$; namely $\hat{\delta}_1 \cap \hat{\delta}_2 = \emptyset$ or $\hat{\delta}_1 \subset \hat{\delta}_2$.

(i₁) Suppose that $\hat{\delta}_1 \cap \hat{\delta}_2 = \emptyset$. Using Remark 4.10, we can see that we must have $y_i \neq z^{\pm 1}$. This finishes the proof of the desired conclusion in this subcase.

(i₂) Suppose that $\hat{\delta}_1 \subset \hat{\delta}_2$. First assume that the endpoints of at least one of $\delta_{1,2}$ approach l from different sides (i.e. one from H_{\pm} and the other from H_{\mp}). Then, again by good position and Definition 4.8, we see that we must have $y_i \neq z^{\pm 1}$. If all endpoints of $\delta_{1,2}$ approach l from the same side then it is possible to have $y_i = z^{\pm 1}$. However, the endpoints of the arc $\tilde{\delta}$ will now approach l from different sides and thus we conclude that $y_{i+1} \neq z^{\pm 1}$. Suppose now that the last letter in c is $z^{\pm 1}$. By part a) of the lemma, it follows that the last canceling pair in c is of type (I) or (II). Thus the endpoints of at least one of $\delta_{1,2}$ approach l from different sides; thus $y_i \neq z^{\pm 1}$. This finishes the proof of the conclusion in case (i).

We now proceed with case (ii). A moment's thought, using the properties of good position, will convince us that the last letter in c is not $z^{\pm 1}$. We first form $[c^{\pm 1}, z^{\pm 1}]$. By good position and Definition 4.8, it follows that the endpoints of the arc $\tilde{\delta}$ representing $[c^{\pm 1}, z^{\pm 1}]$ are now on the same $\alpha_{1,2}$, say on α_1 . Thus both of the endpoints of any arc parallel to $\tilde{\delta}$ must also lie on α_1 . Now the conclusion will follow by our arguments in case (i).

Finally, assume we are in case (iii) above. Again by good position and Definition 4.8 it follows that both endpoints of the arc $\tilde{\delta}$ representing $[c^{\pm 1}, z^{\pm 1}]$ lie outside $\alpha_{1,2}$ and we conclude that $y_i \neq z^{\pm 1}$. \square

In order to continue we need some notation and terminology. We will write $W = [y_1, y_2, y_3, \dots, y_{m+1}]$ to denote the simple (quasi-)commutator

$$W = [\dots [[y_1, y_2], y_3], \dots, y_{m+1}].$$

Let C_1, \dots, C_{m+1} be the sets of letters of Lemma 3.9, for W . Recall that for every $i = 1, \dots, m+1$ the only letter appearing in C_i is $y_i^{\pm 1}$.

Definition 4.14. We will say that the set C_i is bad if there is some $j \neq i$ such that i) we have $y_j = y_i = y$, for some free generator y ; and ii) the crossings on the y -hook, corresponding to a canceling pair $\{y_j, y_j^{-1}\}$ in C_j , are separated by crossings in C_i .

The problem with a bad C_i is that changing the crossings in C_i may not trivialize the arc δ geometrically. For $i = 2, \dots, m+1$, let $c_i = [y_1, \dots, y_{i-1}]$ and let $\delta_{1,2}$ be the parallel arcs representing $c_i^{\pm 1}$ in $[c_i, y_i]$. Let $\bar{\delta} = \delta \setminus (\delta_1 \cup \delta_2)$. We will say that the canceling pair $\{y_i, y_i^{-1}\}$ is admissible if it is of type (I) or (II).

Lemma 4.15. a) Let $W = [y_1, y_2, y_3, \dots, y_{m+1}]$ be a simple quasi-commutator represented by an arc δ in good position and let z be a free generator. Also, let C_1, \dots, C_{m+1} be sets of letters as above. Suppose that C_i is bad and let $\{y_j, y_j^{-1}\}$ be a canceling pair in C_j , whose crossings on the z -hook are separated by crossings in C_i . Suppose, moreover, that the pair $\{y_i, y_i^{-1}\}$ is admissible. Then, with at most one exception, we have $j = i-1$ or $j = i+1$.

b) Let $w(z)$ be the number of the y_i 's in W that are equal to $z^{\pm 1}$. There can be at most $\left\lceil \frac{w(z)}{2} \right\rceil + 1$ bad sets involving $z^{\pm 1}$.

c) For every $j = 2, \dots, m+1$, at least one of $[y_1, \dots, y_{j-1}]$ and $[y_1, \dots, y_j]$ is represented by a good arc.

Proof: a) Let $c = [y_1, \dots, y_{i-1}]$, let $\delta_{1,2}$ be the parallel arcs representing $c^{\pm 1}$ in $[c, y_i]$ and let $\hat{\delta}_{1,2}$ be the arcs of Definition 4.8. Let C_z denote the canceling pair corresponding to $y_i^{\pm 1}$ in $[c, y_i]$. Moreover, let $\bar{\delta} = \delta \setminus (\delta_1 \cup \delta_2)$ and let $\bar{\delta}_c$ denote the union of arcs in $\bar{\delta}$ such that i) each has one endpoint on $\hat{\delta}_1$ and one on $\hat{\delta}_2$ and ii) they do not represent copies of $c^{\pm 1}$ in W . By Lemma 4.9 and Remark 4.10 it follows that $\bar{\delta}_c = \emptyset$.

Without loss of generality we may assume that $j > i$. Also, we may, and will, assume that $y_{i+1} \neq z^{\pm 1}$. First suppose that C_z is of type (II): By Lemma 4.13(a), it follows that if one of $\delta_{1,2}$ has run through the hook part of B then $\bar{\delta} \cap \delta_{1,2} = \emptyset$. Thus the possibility discussed in (a₄) of Remark 4.10 doesn't occur. Now, by Lemma 4.9, it follows that in order for the crossings corresponding to C_z to separate crossings corresponding to a later appearance of $z^{\pm 1}$, we must have i) $y_j = z^{\pm 1}$ realized by a canceling pair of type (II) and ii) the crossings on the z -hook corresponding to y_j and y_j^{-1} lie below (closer to endpoints of the hook) these representing y_i and y_i^{-1} . By Remark 4.10 and the assumptions made above, will convince us that in order for this to happen we must have $\bar{\delta}_c \neq \emptyset$; which is impossible. Suppose C_z is of type (I): Up to symmetries, the configuration for the arc $\bar{\delta}$, representing $[c, y_i]$, is indicated in Figure 10(b). The details in this case are

similar to the previous case except that now the two crossings corresponding to $\{y_i, y_i^{-1}\}$ occur on the same side of the z -hook and we have the following possibility: Suppose that c does not contain any type (II) canceling pairs in z . Then, we may have a type (II) canceling pair $\{y_j, y_j^{\pm 1}\}$, for some $j > i$, such that the crossings in C_z separate crossings corresponding y_j and $\bar{\delta}_c = \emptyset$. This corresponds to the exceptional case mentioned in the statement of the lemma. In this case, the arc representing $[y_1, \dots, y_i, \dots, y_j]$ can be seen to be a *good arc*.

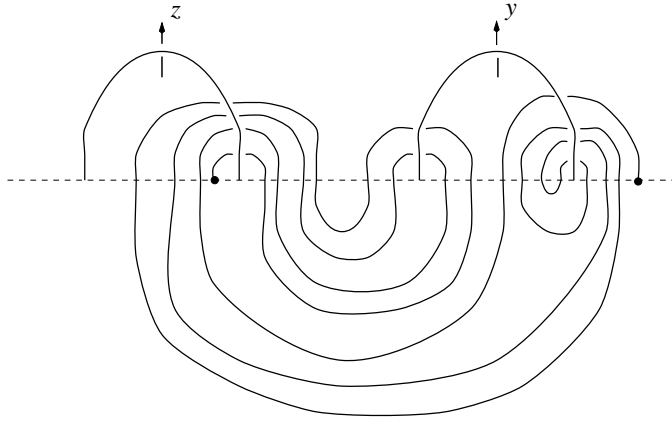

FIGURE 11. Both the endpoints of the arc can be further hooked with the z -hook

An example of an arc where this exceptional case is realized is shown in Figure 11. Here we have $i = 1$. Notice that both endpoints of the arc shown here can be hooked with the z -hook. Thus we can form $[y_1, y, y^{-1}, \dots, y_j, \dots]$, where $y_1 = z$, $y_j = z^{\pm 1}$ and the crossings corresponding to $\{y_j, y_j^{-1}\}$ occur on different endpoints of the z -hook.

b) It follows immediately from part a) and Lemma 4.13(b).

c) Let $d = [y_1, \dots, y_{j-1}]$ and suppose $y_j = y^{\pm 1}$, for some free generator. Then $[y_1, \dots, y_j] = [d, y^{\pm 1}]$. Let δ_1 be the arc representing $[d, y^{\pm 1}]$. A moment's thought will convince us that in order for δ_1 to be bad the following must be true: i) The arc δ_1^* of Lemma 4.11 must intersect the y -hook precisely once; and ii) crossings on the y -hook, corresponding to some appearance of $y^{\pm 1}$ in d , must separate the crossings corresponding to the canceling pair $\{y_j, y_j^{-1}\}$. In particular, $y^{\pm 1}$ must have appeared in d at least once. Moreover it follows from Lemma 4.9 that, for any commutator c , in order to be able to form $[[c, y^{\pm 1}], y^{\pm 1}]$, $[c, y^{\pm 1}]$ must be represented by a good arc. Thus we may assume that d satisfies the following: at least one of the y_i 's is equal to $y^{\pm 1}$; and $y_{j-1} \neq y^{\pm 1}$.

Case 1: Suppose that the arc δ_1 representing $[d, y_j]$ doesn't run through the hook of the band B ; in particular δ_1 is embedded. Then, any canceling pair in d is admissible. From our assumption above, the only remaining possibility is when $\{y_j, y_j^{-1}\}$ corresponds to the exceptional case of part a). As already said in the proof of a), in this case δ_1 is good.

Case 2: Suppose that δ_1 runs through the hook of B . Then,

$$[d, y_j] = [e, y_r, \dots, y_{j-1}, y_j],$$

where i) $\{y_r, y_r^{-1}\}$ is the special canceling pair, and δ_1 runs through the hook at this stage and ii) $e = [y_1, \dots, y_{r-1}]$ is a simple (quasi-)commutator.

Notice that all the canceling pairs corresponding to y_k with $k \neq r$ are admissible, by definition. Let x_0 be the free generator corresponding to the band containing δ . By Lemma 4.9, we see that either $y_r = x_0^{\pm 1}$ or the arc representing $[d, y_j]$ is embedded. In the later case, it follows by Lemma 4.13(a), that δ_1 is embedded and the result follows as in Case 1. If $y_r = x_0^{\pm 1}$, then all the sub-arcs of δ_1 representing e or e^{-1} are embedded; a moment's thought will convince us that are good arcs. Thus if $j = r$, the conclusion of the lemma follows. Suppose $j > r$. By 4.13(a) we have $y_i \neq x_0^{\pm 1}$, for all $i > r$. In particular, $y \neq x_0^{\pm 1}$. Now the conclusion follows as in Case 1. \square

Before we are ready to state and prove the result about good arcs promised in the beginning of §4.3, we need some more notation and terminology. Let $c = [y_1, y_2, \dots, y_{n-1}, y_n]$ and let $\mathbb{C} = \{C_1, C_2, \dots, C_{n-1}, C_n\}$ the sets of letters of Lemma 3.10. We will denote by $||\delta||$ the cardinality of the maximal subset of \mathbb{C} that trivializes δ geometrically; that is δ is $||\delta||$ -nice. We will denote by $s(c)$ the number of bad sets in \mathbb{C} . For a quasi-commutator \hat{c} , we will define $s(\hat{c}) = s(c)$ where c is the commutator underlying \hat{c} . Finally, for $n \in \mathbb{N}$, let $t(n)$ be the quotient of the division of n by four, and let $q(n)$ be the quotient of division by six.

Lemma 4.16. *Suppose that S, B, γ and δ are as in the statement of Proposition 4.4, and that δ_1 is a good subarc of δ representing a simple quasi-commutator c_1 , of length $m + 1$.*

- a) *If δ_1 is embedded then δ_1 is an $t(m + 1)$ -nice arc.*
- b) *If δ_1 is non embedded then δ_1 is an $q(m + 1)$ -nice arc.*

Proof: a) Inductively we will show that

$$||\delta_1|| \geq m + 1 - s(c_1) \tag{1}$$

Before we go on with the proof of (1), let us show that it implies that δ_1 is $t(m)$ -nice.

For a fixed free generator y , let $w(y)$ be the number of appearances of y in c_1 and let $s^y(c_1)$ be the number of bad sets in y . By Lemma 4.15(a), with one exception, a set C_i corresponding to y can become bad only by a

successive appearance of y . By Lemma 4.13, no letter can appear in c_1 more than two successive times. A simple counting will convince us that

$$\frac{w(y)}{s^y(c_1)} \geq \frac{4}{3},$$

and that the maximum number of bad sets in a word is realized when each generator involved appears exactly four times, three of which are bad. Thus we have $s(c_1) \leq m + 1 - t(m + 1)$ and by (1) we see that $\|\delta_1\| \geq t(m + 1)$, as desired.

We now begin the proof of (1), by induction on m . For $m = 1$, we know that all (embedded) arcs representing a simple 2-commutator are nice and thus (1) is true. Assume that $m \geq 2$ and (inductively) that for every good arc representing a commutator of length $\leq m$, (1) is satisfied. Now suppose that

$$c_1 = [[c, z^{\pm 1}], y^{\pm 1}]$$

where c is a simple commutator of length $m - 1$, and z, y are free generators.

Let $\bar{\delta}_{1,2}$ (resp. $\bar{\theta}_{1,2,3,4}$) denote the subarcs of δ_1 representing $[c^{\pm 1}, z^{\pm 1}]^{\pm 1}$ (resp. $c^{\pm 1}$).

Case 1. The arcs $\bar{\delta}_{1,2}$ are good. By induction we have

$$\|\bar{\delta}_{1,2}\| \geq m - s(\bar{c}), \quad (2)$$

where $\bar{c} = [c, z^{\pm 1}]$. Since δ_1 is good, a set of crossings that trivializes $\bar{\delta}_{1,2}$ can fail to work for δ_1 only if it becomes a bad set in c_1 . Moreover, the set of crossings corresponding to the last canceling pair $\{y^{\pm 1}, y^{\mp 1}\}$ of c_1 , also trivializes δ_1 geometrically. By 4.15(a) forming c_1 from $[c, z^{\pm 1}]$ can create at most two bad sets, each involving $y^{\pm 1}$. Thus we have $s(\bar{c}) \leq s(c_1) \leq s(\bar{c}) + 2$. Combining all these with (2), we obtain

$$\|\delta_1\| \geq \|\bar{\delta}_{1,2}\| + 1 - 2 \geq m + 1 - s(\bar{c}) - 2 \geq m + 1 - s(c_1),$$

which completes the induction step in this case.

Case 2. Suppose that $\bar{\delta}_{1,2}$ are not good arcs. Let us use $\bar{\theta}$ to denote any of $\bar{\theta}_{1,2,3,4}$. Suppose that $c = [c_2, x]$, and thus $c_1 = [[[c_2, x], z^{\pm 1}] y^{\pm 1}]$. By Lemma 4.15(c), $\bar{\theta}$ is a good arc and by induction

$$\|\bar{\theta}\| \geq m - 1 - s(c). \quad (3)$$

First suppose that $y \neq z^{\pm 1}$. Because $\bar{\delta}_{1,2}$ are not good we can't claim that the pair $\{z^{\pm 1}, z^{\mp 1}\}$ trivializes $\bar{\delta}_{1,2}$ geometrically; however it will work for δ_1 . Moreover, the set of crossings corresponding the last canceling pair $\{y^{\pm 1}, y^{\mp 1}\}$ of c_1 , also trivializes δ_1 geometrically. Notice that the only sets of crossings that work for $\bar{\theta}$ but could fail for δ_1 are these involving $z^{\pm 1}$ or $y^{\pm 1}$ that correspond to bad pairs in δ_1 . We see that

$$s(c) \leq s(c_1) \leq s(c) + 4.$$

Combining all these with (3), we obtain

$$\|\delta_1\| \geq \|\bar{\theta}\| + 2 - 4 \geq m + 1 - s(c_1),$$

which completes the induction step in this case.

Now suppose that $y = z$. In this case we can see that $s(c) \leq s(c_1) \leq s(c) + 2$ and that at least one of the two last canceling pairs c_1 will trivialize δ_1 geometrically. These together with (3) imply (1). This finishes the proof of part a) of our lemma.

b) Let x_0 denote the free generator of π corresponding to it. If c_1 doesn't involve x_0 at all, δ_1 has to be an embedded good arc and the conclusion follows from part a). So we may suppose that δ_1 involves x_0 . Now the crossings that correspond to appearances of x_0 in c_1 may fail to trivialize the arc geometrically.

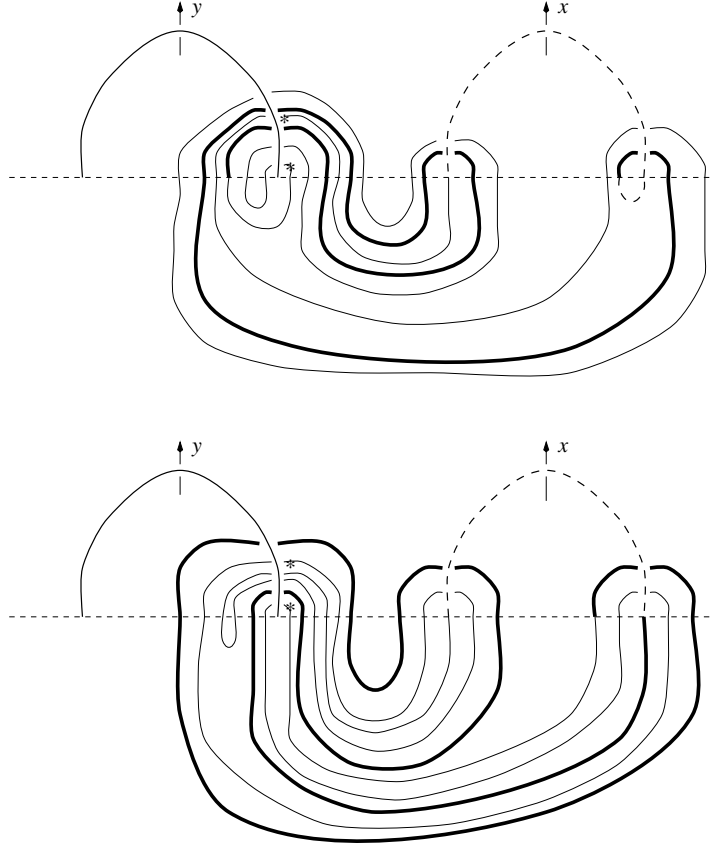

FIGURE 12. Simple commutators occupying the entire band

See, for example the arcs in Figure 12; in both cases crossings that realize the contributions of x_0 fail to trivialize the band. As a result of this, we can

only claim that

$$\|\delta_1\| \geq m + 1 - (s^*(x_0) + w(x_0)), \quad (4)$$

where $w(x_0)$ denotes the number of appearances of x in c_1 and $s^*(x_0)$ is the number of the bad sets in generators different than x_0 .

The proof of (4) is similar to that of (1) in part a). Now by Lemmas 4.13 and 4.15 it follows that the word c_1 that will realize the maximum number of bad sets has the following parity:

$$[x_0, y_1, y_1, x_0, x_0, \dots, y_k, y_k, x_0, x_0, y_1, y_1, \dots, y_k, y_k],$$

where y_1, \dots, y_k are distinct and $x_0 \neq y_i$. Moreover, three out of the four appearances of each y_i correspond to bad sets. Now the conclusion follows. \square

4.5. Conflict sets and products of good arcs. In this subsection we study arcs that decompose into products of good arcs. The punch-line is Lemma 4.20, in which we show that an arc $\tilde{\delta}$ that is a product of good arcs is $q_{\tilde{\delta}}$ -nice.

Let S, B, γ and δ be as in the statement of Proposition 4.4, and let $\tilde{\delta}$ be a subarc of γ representing a word W_1 in $\pi^{(m+1)}$. Suppose that $W_1 = \hat{c}_1 \dots \hat{c}_s$, is a product of quasi-commutators represented by arcs $\{\delta_1, \dots, \delta_s\}$, respectively. Also, for $k = 1, \dots, s$, let $\mathbb{C}_k = \{C_1^k, \dots, C_{(m+1)}^k\}$ be the sets of crossings of Lemma 3.10 for δ_i . Let $C \in 2^{\mathbb{C}_k}$; by assumption the set of letters in C trivialize W_1 algebraically. For a proper subset $\mathbb{D} \subset \{\delta_1, \dots, \delta_s\}$ we will use $C \cap \mathbb{D}$ (resp. $C \cap \bar{\mathbb{D}}$) to denote the crossings in C that lie on arcs in \mathbb{D} (resp. in $\bar{\mathbb{D}}$). Here, $\bar{\mathbb{D}}$ denotes the complement of \mathbb{D} in the set $\{\delta_1, \dots, \delta_s\}$.

For every free generator, say y , we may have crossings on the y -hook, realizing letters in the word W_1 , that trivialize geometrically some of the subarcs δ_i but fail to trivialize $\tilde{\delta}$. To illustrate how this can happen, consider the arcs δ_1 and δ_2 . Let C^1 and C^2 be sets of crossings, on the y -hook, along δ_1 and δ_2 , respectively. Suppose that C^i trivializes δ_i geometrically (i.e. it is a good set of crossings). Suppose, moreover, that there are crossings on δ_2 corresponding to a canceling pair $\{y^{\pm 1}, y^{\mp 1}\}$ that doesn't belong in C^2 , and such that they are separated by crossings in C^1 . Then $C^1 \cup C^2$ may not trivialize $\delta_1 \cup \delta_2$. With the situation described above in mind, we give the following definition.

Definition 4.17. *A set C of crossings on $\tilde{\delta}$ is called a conflict set iff i) the letters in C trivialize W_1 algebraically; ii) switching the crossings in C doesn't trivialize $\tilde{\delta}$ geometrically; and iii) there exists a proper subset $\mathbb{D}_C \subset \{\delta_1, \dots, \delta_s\}$ such that $C \cap \mathbb{D}_C$ trivializes geometrically the union of arcs in \mathbb{D}_C and $C \cap \bar{\mathbb{D}}_C$ trivializes geometrically the union of arcs in $\bar{\mathbb{D}}_C$.*

Lemma 4.18. For $k = 1, \dots, s$, let \hat{c}_k be simple (quasi-)commutator represented by an arc δ_k , and let $\{C_1^k, \dots, C_{(m+1)}^k\}$ be sets of crossings as above. Moreover let $[y_1^k, y_2^k, y_3^k, \dots, y_{m+1}^k]$ be the underlying commutator of \hat{c}_k . Suppose that for some $i = 1, \dots, m+1$, $y_i^k = y_i^{\pm 1}$ for some free generator y , and that $C_i = \cup_{k=1}^s C_i^k$, is a conflict set. Let \mathbb{D}_{C_i} be as in Definition 4.17. Then, there exist arcs $\delta_t \in \mathbb{D}_{C_i}$ and $\delta_r \in \bar{\mathbb{D}}_{C_i}$ such that the crossings on the y -hook corresponding to canceling pairs in y_j^r on δ_r , are separating by crossings corresponding to y_i^t on δ_t . Here $j \neq i$.

With the notation as in Lemma 4.18 the set C_j^r will be called a *conflict partner* of C_i^t .

Lemma 4.19. Let $W_{1,2} = [y_1^{1,2}, y_2^{1,2}, y_3^{1,2}, \dots, y_{m+1}^{1,2}]$ be the underlying commutators of quasi-commutators represented by arcs $\delta_{1,2}$. Let C_i^1 and C_j^2 be sets of letters in W_1 and W_2 respectively, corresponding to the same free generator y . Suppose that C_j^2 is a conflict partner of C_i^1 . Then, with at most one exception,

- (1) either $j = i + 1$ (resp. $j = i - 1$) and $y_k^1 = y_k^2$ for $k < i$ (resp. for $k < i - 1$); or
- (2) the sets of free generators appearing in $\{y_1^1, \dots, y_i^1\}$ (resp. $\{y_1^1, \dots, y_j^1\}$) and $\{y_{i+1}^2, \dots, y_{j-1}^2\}$ (resp. $\{y_{j+1}^2, \dots, y_{i-1}^2\}$), are disjoint.

Proof: By 4.18, there must be crossings on the y -hook corresponding to canceling pairs in C_j^2 , that are separated by crossings in C_i^1 . Let C_1 denote the canceling pair corresponding to y_i^1 in $[y_1^1, y_2^1, \dots, y_i^1]$. and let C_2 denote the canceling pair corresponding to y_i^2 (resp. y_j^2) in $[y_1^2, y_2^2, \dots, y_i^2]$ (resp. $[y_1^2, y_2^2, \dots, y_j^2]$) if $j > i$ (resp. $j < i$). By Lemma 4.13(a), $C_{1,2}$ are of type (I) or (II). Let $D_{1,2}$ be the finite disc corresponding to the canceling pair $C_{1,2}$, in $W_{1,2}$, respectively. Up to symmetry there are three cases to consider: i) Both $C_{1,2}$ are of type (I); ii) both $C_{1,2}$ are of type (II); and iii) one of them is of type (I) and the other of type (II). In each case the result will follow using Remark 4.10 to study the components of $D_{1,2} \cap \bar{\delta}_{1,2}$, where $\bar{\delta}_{1,2}$ denotes the complement in $\delta_{1,2}$ of the parallel arcs corresponding to $C_{1,2}$, respectively. The exceptional case will occur when the canceling pair C_1 is of type (I) and crossings in it are separated by a type (II) canceling pair on δ_2 . The details are similar to these in the proof part a) of Lemma 4.15 \square

To continue, recall the quantity $q_{\bar{5}}$ defined before the statement of Proposition 4.4.

Lemma 4.20. (Products of good arcs) Let S, B, γ and δ be as in the statement of Proposition 4.4, and let $W = c_1 \dots c_r$ be a word expressing δ^+ as a product of simple quasi-commutators. Suppose that $\tilde{\delta}$ is a subarc of δ , representing a subword of simple quasi-commutators $W_1 = \hat{c}_1 \dots \hat{c}_s$, each of

which is represented by a good arc. Then $\tilde{\delta}$ is $q_{\tilde{\delta}}$ -nice. In particular if W is a product of simple quasi-commutators represented by good arcs, Proposition 4.4 is true for δ .

Proof: If $s = 1$ the conclusion follows from Lemma 4.16. Assume that $s > 1$. Let $\delta_1, \dots, \delta_s$ be arcs representing $\hat{c}_1 \dots \hat{c}_s$, respectively.

In general, we may have conflict sets of crossings between the δ_j 's. Since conflict sets occur between commutators that have common letters, we must partition the set $\{\hat{c}_1, \dots, \hat{c}_s\}$ into groups involving disjoint sets of generators and work with each group individually. The maximum number of conflicts will occur when all the \hat{c}_i 's belong in the same group. Since conflict sets are in one to one correspondence with proper subsets of $\{\delta_1, \dots, \delta_s\}$, the maximum number of conflict sets, for a fixed generator y , is $2^s - 2$.

Let x_0 be the generator corresponding to the hook of B . From the proof of Lemma 4.16, and by Lemma 4.19 we can see that a word W , in which there are k distinct generators besides $x_0^{\pm 1}$, will realize the maximum number of bad sets of crossings on the individual δ_i 's and the maximum number of conflict sets, if the following are true:

- i) The length $m + 1$ is equal to $6k + r + 2k(2^s - 2)$, where $r > 2$;
- ii) each of the arcs δ_i realizes the maximum number of bad sets and the maximum number of appearances of $x_0^{\pm 1}$ (i.e. $5k + \frac{r}{2}$) and there are $k(2^s - 2)$ conflict sets between the δ_i 's. Moreover, each pair of conflict partners in W correspond either to the exceptional case or in case (1) of Lemma 4.19.

We claim, however, that there will be $k + \left\lceil \frac{r}{2} \right\rceil + k(s - 2)$ sets of crossings that trivialize $\tilde{\delta}$ geometrically. From these $k + \left\lceil \frac{r}{2} \right\rceil$ come from good sets on the δ_i 's. The rest $ks - 2k$ are obtained as follows: For a fixed $y \neq x_0^{\pm 1}$, the crossings in the conflict sets involving $y^{\pm 1}$ and in their conflict partners can be partitioned into $s - 2$ disjoint sets that satisfy the definition of $(s - 3)$ -triviality. To see that, create an $s \times (2^s - 2)$ matrix, say A , such that the (i, j) entry in A is the j -th appearance of y in \hat{c}_i . The columns of A are in one to one correspondence with the conflict sets $\{C_i\}$, in y . By 4.19, and 4.13 there are at most $2s$ "exceptional" conflict partners shared among the C_i 's. Other than that, the conflict partners of a column C_i will lie in exactly one of the adjacent columns. For $s \geq 4$ we have $2^s - 2 \geq 4s$ and thus A has at least $2s$ columns that can only conflict with an adjacent column; these will give $s > s - 2$ sets as claimed above. For $s = 2, 3$ the conclusion is trivial.

Now from i) we see that $ks - 2k > \log_2\left(\frac{m + 1 - 4k - r}{4}\right)$. Thus,

$$\frac{r}{2} + k(s - 2) > \log_2\left(\frac{m + 1 - 4k}{4}\right) > \log_2\left(\frac{m + 1 - 6k}{6}\right),$$

and the claim in the statement of the lemma follows. \square

4.6. The reduction to nice arcs. Let S, B, γ and δ be as in the statement of Proposition 4.4. Our goal in this paragraph is to finish the proof of the proposition. We begin with the following lemma, which relates the q_μ -niceness of a subarc $\mu \subset \tilde{\delta} \subset \delta$ to the $q_{\tilde{\delta}}$ -niceness of $\tilde{\delta}$.

Lemma 4.21. (Products of nice arcs) *Let S, B, γ and δ be as in the statement of Proposition 4.4. Let $\tilde{\delta}$ be a subarc of δ , representing a subword $W_1 = \hat{c}_1 \dots \hat{c}_s$, where \hat{c}_i is a product of simple quasi-commutators represented by an arc θ_i . Suppose that θ_i is q_{θ_i} -nice, for $i = 1, \dots, s$. Then $\tilde{\delta}$ is $q_{\tilde{\delta}}$ -nice.*

Proof: Once again we can have sets of crossings on $\tilde{\delta}$ that trivialize W_1 , and trivialize a subset of $\{\theta_1, \dots, \theta_s\}$ geometrically but fail to trivialize $\tilde{\delta}$. For $i = 1, \dots, s$, let m_i denote the number of simple quasi-commutators in \hat{c}_i , and let \mathbb{D}_i denote the set of subarcs of $\tilde{\delta}$ representing them. We notice that the maximum number of conflict sets that we can have in W_1 , is $k[2^{(m_1 + \dots + m_s)} - 2]$ where k is the number of distinct generators, different than x_0 , appearing in W . Now we may proceed as in the proof of Lemma 4.20. \square

To continue recall the notion of a quasi-nice arc (Definition 4.5). Our last lemma in this section shows that the notions of quasi-nice and $q_{\tilde{\delta}}$ -nice are equivalent.

Lemma 4.22. *A quasi-nice subarc $\tilde{\delta} \subset \delta$ that represents a product $W = c_1 \dots c_r$ of quasi-commutators, is $q_{\tilde{\delta}}$ -nice.*

Proof: Let $\delta_1, \dots, \delta_r$ be the arc representing c_1, \dots, c_r , respectively. Let \mathbb{D}_g (resp. \mathbb{D}_b) denote the set of all good (resp. not good) arcs in $\{\delta_1, \dots, \delta_r\}$. Also let n_g (resp. n_b) denote the cardinality of \mathbb{D}_g (resp. \mathbb{D}_b). If $n_b = 0$, the conclusion follows from Lemma 4.20. Otherwise let $\mu \in \mathbb{D}_b$, be the first of the δ_i 's not represented by a good arc. Suppose it represents $c_\mu = [c^{\pm 1}, y^{\mp 1}]$, where $c^{\pm 1}$ is a simple quasi-commutator of length m , and y a free generator. Let μ^1, μ^2 be the subarcs of μ representing $c^{\pm 1}$. Since μ is not good, y must have appeared in c ; thus the numbers of distinct generators in the words representing μ and μ^1, μ^2 are the same. We can see that $q_{\mu^1} = q_{\mu^2} = q_\mu$. By 3.14, μ^1, μ^2 are good arcs and by Lemma 4.16 they are q_μ -nice. Let $\bar{\mu} = \tilde{\delta} \setminus \mu$, and let $\bar{\mu}_{1,2}$ denote the two components of $\bar{\mu}$. By induction and 4.21, $\bar{\mu}_i$ is $q_{\bar{\mu}_i}$ -nice. Since μ is not good, one of its endpoints lies inside the y -hook and the other outside. Moreover the arc μ^* of Lemma 4.11, separates crossings corresponding to canceling pairs on the y -hook. Now a moment's thought will convince us that at least one of $\bar{\mu}_{1,2}$ must have crossings on the y -hook. A set of crossings that trivializes geometrically $\theta_1 = \mu^1 \cup \mu^2$ and $\theta_2 = \bar{\mu}_1 \cup \bar{\mu}_2$ will fail to trivialize $\tilde{\delta}$ only if there are conflict sets between θ_1 and θ_2 . A counting argument shows that the maximum number of conflict sets that can be on $\tilde{\delta}$ is $k(2^r - 2)$, where k is the number of distinct generators, different than x_0 , in W . Now the conclusion follows as in the proof of 4.21. \square

Proof: [of Proposition 4.4] It follows immediately from 4.22 and the fact that the arc δ in the statement of 4.4 is quasi-nice; see discussion in §4.3. \square

Remark 4.23. Theorem 4.2 is not true if we don't impose any restrictions on the surface S of Definition 4.1. For example let K be a positive knot set $\pi_K = \pi_1(S^3 \setminus K)$ and let D_K denote the untwisted Whitehead double of K . Let S be the standard genus one Seifert surface for $D(K)$. Since $\pi_K^{(n)} = \pi_K^{(2)}$ for any $n \geq 2$, we see that S has a half basis realized by a curve that if pushed in the complement of S lies in $\pi_K^{(n)}$, for all $n \geq 2$. On the other hand, D_K doesn't have all its Vassiliev invariants trivial since it has non-trivial 2-variable Jones polynomial (see for example [Ru]).

REFERENCES

- [AK] E. Kalfagianni and N. Askitas, *On n -adjacent knots*, Topology Appl. 126 (2002), no. 1-2, 63–81.
- [Bi] J. S. Birman, *New points of view in knot theory*, Bull. of AMS, 28(1993), 253–287.
- [BN1] D. Bar-Natan, *On the Vassiliev knot invariants*, Topology, 3(1995), 423–472.
- [CT] J. Conant and P. Teichner, *Grope cobordism of classical knots*. Topology 43 (2004), no. 1, 119–156.
- [BN2] D. Bar-Natan, *Vassiliev homotopy string link invariants*, J. of Knot Theory and Ramifications, 4(1995), 13–32.
- [Gu] M. N. Gusarov, *On n -equivalence of knots and invariants of finite degree*, in *Topology of Manifolds and Varieties*, 173–192, Adv. Soviet Math., vol. 18, AMS, 1994.
- [Ha] K. Habiro, *Claspers and finite type invariants of links*, Geom. Topology 4 (2000) 1–83.
- [He] J. Hempel, *3-manifolds*, Annals of Mathematics Studies, vol. 86, Princeton University Press, 1976.
- [KL] E. Kalfagianni and X.-S. Lin, *Regular Seifert surfaces and Vassiliev knot invariants*, at ArXiv math.GT/9804032.
- [KSM] A. Karras, W. Magnus and D. Solitar *Combinatorial Group Theory*, Pure and Appl. Math., vol. XIII, Interscience, NY, 1966.
- [NS] K.-Y. Ng and T. Stanford: *On Gussarov's groups of knots*, Math. Proc. Camb. Phil. Soc., 126 (1999), no. 1, 63–76.
- [P] L. Plachta, *Double trivalent diagrams and n -hyperbolic knots*, Methods Funct. Anal. Topology 10 (2004), no. 2, 43–56.
- [P1] L. Plachta, *Geometric aspects of invariants of finite type of knots and links in S^3* , Mat. Stud. 18 (2002), no. 2, 213–222.
- [S] T. Stanford, *Braid commutators and Vassiliev invariants*, Pacific J. Math. 174 (1996).
- [S1] T. Stanford, *Vassiliev invariants and knots modulo pure braid subgroups*, at ArXiv math.GT/9805092
- [Ro] D. Rolfsen: *Knots and Links*, Publish or Perish, 1976.
- [Ru] L. Rudolph: *A congruence between link polynomials*, Math. Proc. Camb. Phil. Soc., **107** (1990), 319–327.

DEPARTMENT OF MATHEMATICS, WELLS HALL, MICHIGAN STATE UNIVERSITY, E. LANSING, MI, 48823

E-mail address: kalfagia@math.msu.edu